

PRODUCT:	QTY:	ITEM #:
----------	------	---------



FaHEATER MCF-100, MCF-200

Standard Features:

- Portable tabletop design with 18 gauge 304 stainless steel housing, heavy duty electronic components, and high impact ceramic glass top designed for use in the commercial kitchen.
- Microprocessor monitors vital components 120 times per second to check for overheating, power supply problems, and more. Cooktop shuts off and displays error codes enabling user to diagnose and fix minor problems.
- User friendly membrane panel is easy to operate and understand.
- LED Display for precise user feedback
- Sloped front panel allows for easy viewing and operation
- Easy-to-clean glass top surface
- Integral cooling fan keeps internal electronics cool
- Available in 120V and 208-240V
- One year limited warranty
- Made-in-the-USA

Specifications:

Shall be a CookTek free-standing induction cooktop, Model _____ with a total kW rating of _____. Unit shall be manufactured in the United States and constructed of a stainless steel housing and a high impact ceramic glass top. Unit shall be equipped with auto shut-off to prevent overheating, self diagnostics, Unit shall operate on _____ power with integral cord and plug supplied.

OPTIONS AT NO CHARGE:

NEMA plug type standard for U.S. and Canadian destinations. All other countries must specify voltage, duty cycle and required NEMA plug configuration.

CookTek
810 West Washington Blvd.
Chicago, Illinois 60607 USA
www.cooktek.com

Tel: 1.312.563.9600 Fax: 1.312.432.6220
Toll Free: 1.888.COOKTEK (266-5835)
Toll Free Fax: 1.888.COOKFAX (266-5329)



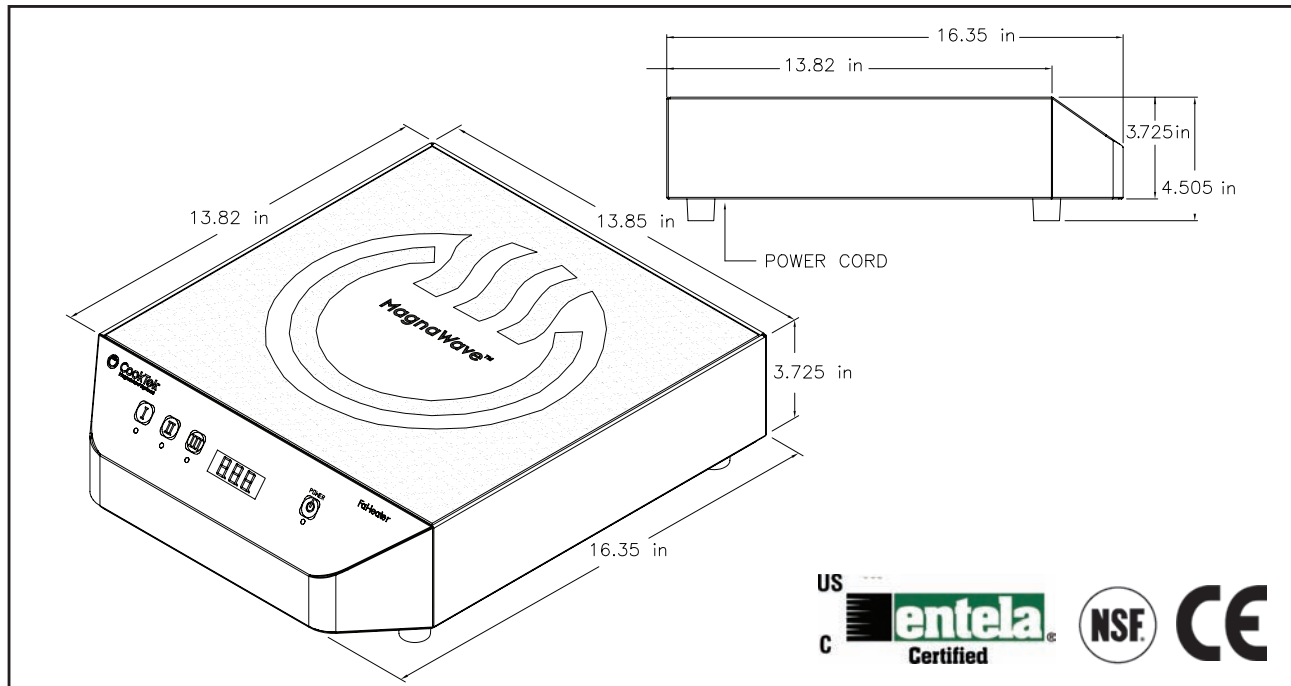

SPECIFICATIONS

	MCF-100	MCF-200
Model Number	MCF-100	MCF-200
Power requirements	100-120V	1PH 200-240V
Power consumption	1800 Watts (at max. setting)	4000 Watts (at max. setting)
Voltage	100-120V 50/60Hz	200-240V 50/60Hz
Amperage	15 amps (at max. setting)	20 amps (at max. setting)
Power range	900W - 1700W	600W-4000W
Charger dimensions (Inches)	16.35L x 13.85W x 4.50H	16.35L x 13.85W x 4.50H
Weight	19 lbs.	19 lbs.
Packaged Weight	24 lbs.	24 lbs.
Packaged Dimensions (Inches)	20.75L x 18.75W x 9.0H	20.75L x 18.75W x 9.0H
Cord length & Plug type	6 Ft., NEMA 5-15P	6 Ft., NEMA 6-20P
Warranty	One year limited warranty	One year limited warranty
Cooling clearance	2" front, rear and sides	2" front, rear and sides

Note: Many local codes exist, and it is the Owner and Installer's responsibility to comply with those codes. It's CookTek's policy to continually improve its products, and we reserve the right to change or improve our specifications without notification.

CookTek
810 West Washington Blvd.
Chicago, Illinois 60607 USA
www.cooktek.com

Tel: 1.312.563.9600 Fax: 1.312.432.6220
Toll Free: 1.888.COOKTEK (266-5835)
Toll Free Fax: 1.888.COOKFAX (266-5329)

