



*Accelerating the World of Cooking™*

# Owner's Manual

FOR THE TURBOCHEF 3240 HIGH H CONVEYOR OVEN





For further information, call  
800.90TURBO  
or  
+1 214.379.6000

The information contained in this manual is important for the proper installation, use, maintenance, and repair of this oven. Follow these procedures and instructions to help ensure satisfactory baking results and years of trouble-free service.

Errors – descriptive, typographic, or pictorial – are subject to correction. Specifications are subject to change without notice.

**PLEASE CAREFULLY READ THIS MANUAL AND RETAIN IT FOR FUTURE REFERENCE.**

# Table of Contents

## Safety Instructions

Important Safety Information - Please Read First	i
General Safety Information	i
Preventing Oven Damage	i
Reducing Fire Risk	ii
Grounding Instructions	ii
Power Cord Replacement	ii

## Specifications

Oven Overview	1
Certifications	2
Dimensions	2
Oven Construction	2
Power Specifications	2
Theory of Operation	2
Bake Time vs. Time of Delivery	3

## Cleaning

Daily Cleaning Procedures	4
Deep Cleaning Procedures	5-7

## Standard Oven Operation

Oven Controls	7
Cooking a Product	8
Editing a Cooking Profile	10
-Changing a Cooking Profile's Name	10
-Adjusting the Belt Speed	10
-Adjusting the Temperature	11
-Adjusting the Top and Bottom Air	11

## Oven Modes

Config Mode	12
-Smart Card Screen	12
-Fault Count Screen	12
-Test Mode	12

Setup Mode	12
-Changing the Temperature Measurement Setting	13
-Edit Option Screen	13
-Changing the Language	13
-Info Screen	13
Troubleshooting	14
North America Limited Warranty	17
International Limited Warranty	20

## Important Safety Information – Please Read First

Improper installation, adjustment, alteration, service, or maintenance of this equipment can cause property damage, injury, or death. Thoroughly read the installation, operating, and maintenance instructions before installing, operating, or cleaning this equipment. The control board, blower and conveyor drives, and gas valve are all adjusted by TurboChef or an Authorized Service Agent, no further adjustment is required. Strictly adhere to the following safety information to reduce the risk of:

- Damage to the oven
- Damage to property near the oven
- Personal injury
- Burns
- Fire
- Electric shock

## General Safety Information

- ✓ Use this appliance only for its intended uses as described in this manual.
- ✓ From your local gas provider, obtain instructions for what to do if gas odors are detected and post them in a prominent location.
- ✓ Only qualified service personnel should service this appliance. Contact the nearest authorized service facility for examination, repair, or adjustment.
- ✓ Always ensure the oven is disconnected from the power supply before servicing, repairing, or adjusting any components or parts.
- x DO NOT place the cord near heated surfaces.
- x DO NOT store or use flammable vapors or liquids (e.g., gasoline) in the vicinity of this appliance.
- x DO NOT allow children to use this appliance.
- x DO NOT place corrosive chemicals or vapors in this appliance. It is not designed for industrial or laboratory use.
- x DO NOT operate this appliance if it:
  - Has a damaged cord, plug, or gas hose
  - Is not working properly
  - Has been damaged or dropped
- x DO NOT cover or block any openings on this appliance.
- x DO NOT store this appliance outdoors.
- x DO NOT use this appliance near water.
- x DO NOT immerse this appliance or any of its components (e.g., cord, plug, etc.) in water.
- x DO NOT work near the appliance with long hair, loose clothing, or dangling jewelry.

## Preventing Oven Damage

- ✓ Clean the oven daily.
- ✓ Clean the oven only with TurboChef approved cleaner.
- x DO NOT clean with a water jet.
- x DO NOT slam or mishandle the oven window.
- x DO NOT frequently open and close the window to check the cook status of the food.
- x DO NOT allow cleaning solution or water to remain in the cook cavity longer than necessary.

## Reducing Fire Risk

If materials inside the oven ignite or if smoke is observed,

1. Keep the oven window closed.
2. Turn off the oven.
3. Disconnect the power cord or shut off power at the fuse/circuit breaker panel.

- ✓ Carefully attend the oven if paper, plastic, or other combustible materials are placed inside the oven to facilitate cooking.
- x DO NOT leave items in the cook cavity when the oven is not in use.
- x DO NOT cook items wrapped in cling wrap or plastic film.
- x DO NOT overcook food.
- x DO NOT store (or use) gasoline or any other flammable vapors or liquids near this appliance, other than the properly-connected gas or propane supply to the oven.

If a gas leak is noticed,

- x DO NOT attempt to light or operate any appliance.
- x DO NOT operate any electronic device.
- ✓ Immediately use an exterior phone to contact your gas supplier.
- ✓ If you cannot contact your gas supplier, contact your local fire department.

## Grounding Instructions

 **WARNING:** Improper grounding increases the risk of electric shock.

This appliance must be grounded. The cord is equipped with a grounding wire and plug, which in the event of an electrical short circuit, reduce the risk of electric shock by providing an escape wire for the electric current. The wire must be plugged into an outlet that is properly installed and grounded.

Consult a qualified electrician or serviceman to determine whether or not the appliance is properly grounded.

- x DO NOT use an extension cord. If the power supply cord is too short, request a qualified electrician or serviceman to install an outlet near the appliance.

## Power Cord Replacement

To avoid potential hazards, only the manufacturer, its service agent, or a similarly-qualified person should replace a damaged power cord.

## Oven Overview

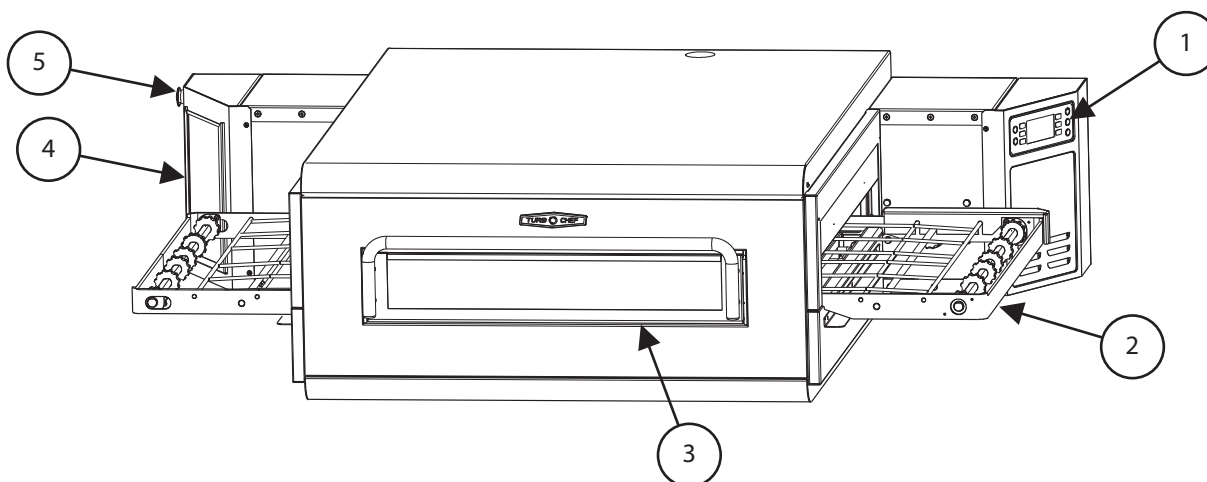

Figure 1: Oven Overview

### 1. Controls

The controls are located on the right side of the oven. For more information, refer to page 7.

### 2. Conveyor

The speed of the conveyor is controlled within the cooking mode when edit or flex is enabled. For more information, refer to page 10. The conveyor may be installed with the belt rotating from left to right or right to left. **DO NOT** operate the oven without the conveyor installed. The conveyor is removable for cleaning and service purposes only.

### 3. Window

The window (available on select models) is used for checking the cook progress of food items. **DO NOT** operate the oven for extended periods of time with the window open.

**⚠ CAUTION:** **DO NOT** place your hand inside the oven; temperatures within the oven can exceed 550°F (288°C).

### 4. Air Filters

The air filters are located on the left side of the oven. Clean the air filters daily to maintain normal oven operation (page 4). Replace the air filters immediately if they are torn or damaged. **DO NOT** operate the oven without the air filters installed.

### 5. Idle Button

The idle button is located on the left side of the oven. Press the idle button to activate the **IDLE MODE** (page 9). The idle button lights up when the oven is in idle mode.

**NOTE:** When the idle button is pressed, the conveyor will continue running for the amount of time defined by the belt speed and will then enter the **IDLE MODE**.

## Certifications

cULus GAS FIRED LISTED, UL EPH, FCC

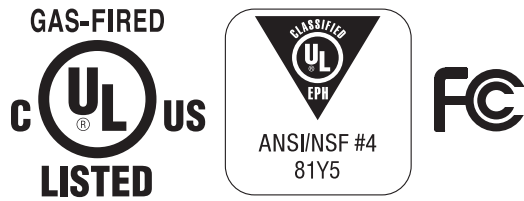

## Dimensions

### With End-Bells Closed

- Width: 72.13" (1832mm)
- Depth: w/ window: 55.25" (1403mm)
- Depth: w/o window: 52.85" (1342mm)
- Height: 19.00" (483mm)

### With End-Bells Open

- Width: 87.53" (2223mm)
- Depth: w/ window: 59.20" (1504mm)
- Depth: w/o window: 56.80" (1443mm)
- Height: 19.00" (483mm)

## Oven Construction

- 430 stainless steel exterior
- 304 stainless steel interior
- Powder coated steel legs

## Power Specifications

### Electrical

	North America	EU/Asia
Phase	1 Phase	1 Phase
Voltage	208/240 VAC	220-240 VAC
Frequency	50/60 Hz	50/60 Hz
Current Draw	8 Amp	8 Amp
Supply	3 Wire (L + L + G)	3 Wire (L + L + G)
Breakers	20 amp	16 amp
Plug	NEMA L620	IEC, 309 3 PIN

### Gas

- Volume: Maximum input per cavity  
85k BTU (25kW [Gross])
- Min. Pressure (Nat, LP, I<sub>2H</sub>, I<sub>2E</sub>, I<sub>2E+</sub>, I<sub>2L</sub>, and I<sub>3P</sub>):  
6" W.C. (152.4 mm H<sub>2</sub>O / 14.94 mb)
- Max. Pressure (Nat, LP, I<sub>2H</sub>, I<sub>2E</sub>, I<sub>2E+</sub>, I<sub>2L</sub>, and I<sub>3P</sub>):  
14" W.C. (350.6 mm H<sub>2</sub>O / 34.87 mb)
- Burner Pressure (Nat, LP, I<sub>2H</sub>, I<sub>2E</sub>, I<sub>2E+</sub>, and I<sub>3P</sub>):  
3.5" W.C. (88.9 mm H<sub>2</sub>O / 8.71 mb)
- Burner Pressure (I<sub>2L</sub>):  
4.0" W.C. (101.6 mm H<sub>2</sub>O / 9.96 mb)

## Theory of Operation

The HhC 3240 oven combines precisely-controlled impinged air and combustion energy to create a highly customizable environment for cooking. The impinged air enters the cavity from the top and bottom, generated by two independently-controlled blower motors.

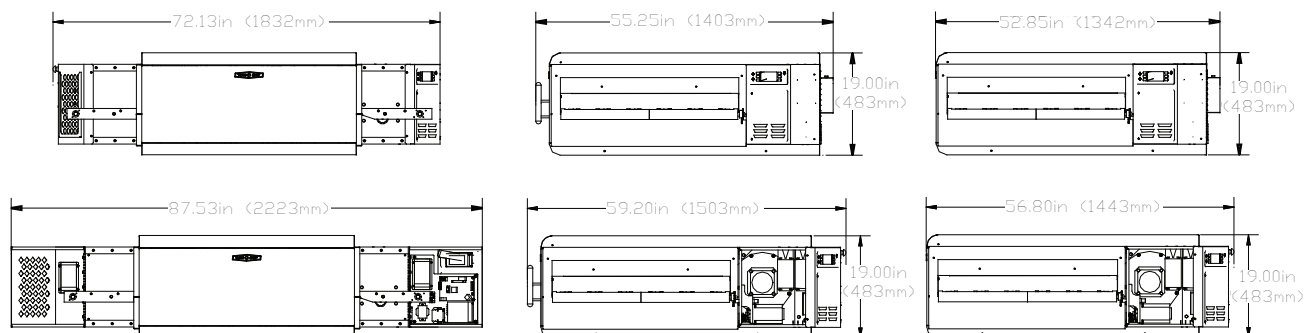

Figure 2: Dimensions

## Bake Time vs. Time of Delivery

Bake time is the time from when the leading edge of the product enters the oven until the leading edge of the product exits the oven. Bake time is a customizable oven setting. Belt F and Belt R (page 10, figure 6) indicate set bake times.

Time of delivery is the time from when the leading edge of the product enters the oven until the trailing edge of the product exits the oven (figure 3). The product is fully discharged and ready for customer delivery once the trailing edge has exited the cook chamber. Use the following formula to determine the time of delivery:

$$\frac{\text{Bake Time}}{\text{Cook Chamber Length}} \times (\text{Cook Chamber Length} + \text{Product Length})$$

To increase output, increase the bake temperature and reduce the bake time; however, this can reduce quality. The product may appear baked on the surface, but the interior may be undercooked or raw.

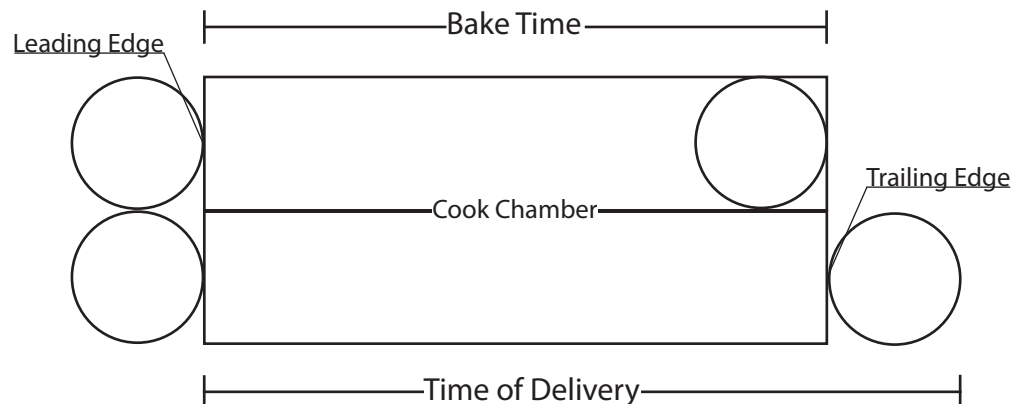

Figure 3: Bake Time vs. Time of Delivery

## Cleaning the Oven

Follow the steps below daily to help maintain your HhC oven.

## Supplies and Equipment

TurboChef-approved oven cleaner, nylon scrub pad, cleaning towels, disposable gloves

### Daily Cleaning Procedures



Step 1

#### Step 1: Prepare the Oven

- Press the back/off key to turn the oven off.
- Ensure cooling down has completed.

**⚠ CAUTION:** Injury can occur if the oven is not allowed to cool properly before cleaning. DO NOT attempt to clean until the “cooling down” message has disappeared.



Step 2

#### Step 2: Remove and Clean the End Trays

- Remove the end trays.
- Wash and rinse the end trays, then dry them with a clean towel.
- Reinstall the end trays.



Step 3

#### Step 3: Remove and Clean the Crumb Trays

- Slide out and remove both crumb trays.
- Wash and rinse both crumb trays, then dry them with a clean towel.
- Reinstall the crumb trays.

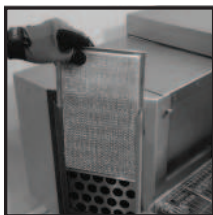

Step 4

#### Step 4: Remove and Clean the Filters

- Remove the filters, both of which are located on the left side of the oven.
- Wash and rinse both filters, then dry them with a clean towel.
- Reinstall the filters.
  - +If a filter is torn or damaged, replace it with a new filter.

**⚠ CAUTION:** DO NOT operate the oven without the filters in place.



Step 5

#### Step 5: Clean the Oven Exterior

- Wipe the oven exterior and window with a clean, damp towel.
- The oven is ready to turn on.

## Deep Cleaning Procedures

TurboChef recommends deep cleaning the oven at least once a month (more frequently depending on use) to ensure optimal performance. Use only TurboChef-approved cleaner. Using any other cleaning product can damage critical parts and may void the oven's warranty.



Step 1

### Step 1: Prepare the Oven

- Press the back/off key to turn the oven off.
- Ensure cooling down has completed.

**⚠ CAUTION:** Injury can occur if the oven is not allowed to cool properly before cleaning. DO NOT attempt to clean until the “cooling down” message has disappeared.



Step 2

### Step 2: Remove and Clean the End Trays

- Remove the end trays.
- Wash and rinse the end trays, then dry them with a clean towel.



Step 3

### Step 3: Remove and Clean the Crumb Trays

- Slide out and remove both crumb trays.
- Wash and rinse both crumb trays, then dry them with a clean towel.

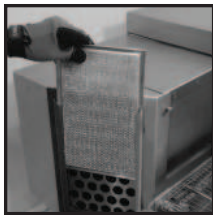

Step 4

### Step 4: Remove and Clean the Filters

- Remove the filters, both of which are located on the left side of the oven.
- Wash and rinse both filters, then dry them with a clean towel.
- +If a filter is torn or damaged, replace it with a new filter.

**⚠ CAUTION:** DO NOT operate the oven without the filters in place.

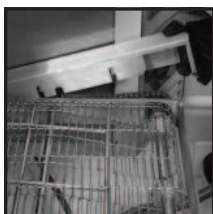

Step 5

### Step 5: Remove and Clean the Chain Guard

- Remove the guard that covers the conveyor drive chain.
- Wash and rinse the chain guard, then dry it with a clean towel.



Step 6

### Step 6: Remove and Clean the Upper End Panels

- Remove both upper end panels from each end of the oven.
- Wash and rinse the upper end panels, then dry them with a clean towel.

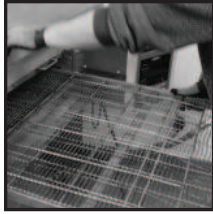

Step 7

**⚠ WARNING:** Lock all 4 casters before removing the conveyor, lower plenum assembly, and upper nozzle plate. Physical injury or damage to equipment can occur if the casters are not locked.

**Step 7: Remove and Clean the Conveyor (requires TWO people)**

- Position one person at each end of the conveyor.
- Lift the conveyor assembly up and then towards the left side of the oven until the conveyor drive chain has enough slack for removal.
- Remove the conveyor drive chain.



Step 8

**⚠ WARNING:** Never attempt to remove the conveyor with fewer than two people.

- Lift the conveyor and push it through the right side of the oven for removal.
- Wash and rinse the conveyor, then dry it with a clean towel.

**Step 8: Remove and Clean the Lower End Panels**

- Remove both lower end panels from each end of the oven.
- Wash and rinse the lower end panels, then dry them with a clean towel.

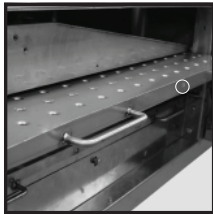

Step 9

**Step 9: Remove and Clean the Upper Nozzle Plate**

- Remove the thumbscrew holding the upper nozzle plate in place on the right side of the oven (located between the two handles). If the right side upper air diverter is incorrectly positioned in front of the lip of the upper nozzle plate, remove the right side upper air diverter.
- Spray the upper nozzle plate with TurboChef Oven Cleaner to break apart any heavy stains. Allow cleaner to penetrate stains for five minutes.
- Scrub the upper nozzle plate with a nylon scrub pad.
- Rinse the upper nozzle plate with water and wipe it with a clean, damp towel.

**⚠ WARNING:** Be sure to THOROUGHLY remove all cleaner residue.

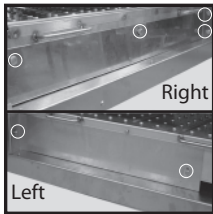

Step 10

**Step 10: Remove and Clean the Right and Left Lower Air Diverters**

- Remove the four thumbscrews from the right side lower air diverter.
- Remove the right side lower air diverter.
- Remove the two thumbscrews from the left side lower air diverter.
- Remove the left side lower air diverter.
- Wash and rinse the lower air diverters, then dry them with a clean towel.



Step 11

**Step 11: Remove and Clean the Lower Plenum Assembly**

- Remove the lower plenum assembly from the right side of the oven.
- Spray the lower plenum assembly with TurboChef Oven Cleaner to break apart any heavy stains. Allow cleaner to penetrate stains for five minutes.
- Scrub the lower plenum assembly with a nylon scrub pad.
- Rinse the lower plenum assembly with water and wipe it with a clean, damp towel.

**⚠ WARNING:** Be sure to THOROUGHLY remove all cleaner residue.



Step 12

**Step 12: Clean the Oven Interior**

- Spray the bottom and sides of the oven interior with TurboChef Oven Cleaner to break apart any heavy stains. Allow cleaner to penetrate stains for five minutes.
- Scrub the oven interior with a nylon scrub pad.
- Wipe the oven interior with a clean, damp towel.

**⚠ WARNING:** Be sure to THOROUGHLY remove all cleaner residue.

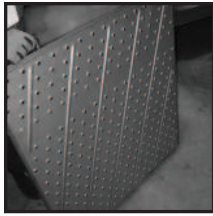

Step 13

### Step 13: Reinstall the Oven Components

- Reinstall the lower plenum assembly.
- Reinstall the lower air diverters.
- Reinstall the upper nozzle plate (reinstall the right side upper air diverter if necessary).
- Reinstall the lower end panels.
- Reinstall the conveyor and chain.
- Reinstall the upper end panels.
- Reinstall the chain guard, filters, and crumb trays.



Step 14

### Step 14: Clean the Oven Exterior

- Wipe the oven exterior and window with a clean, damp towel.
- The oven is ready to turn on.

## Oven Controls

Figure 4

### 1. Display

The display shows current oven operation and/or user programming information.

### 2. Soft Keys

Six soft keys are on the oven controls, three on the left (L1, L2, L3, where L1 = top) and three on the right (R1, R2, R3, where R1 = top). Press a soft key to select the option/command that is adjacent to it on the screen.

### 3. Up and Down Keys

When the oven is in the OVEN OFF or COOLING DOWN MODE, use the up key to access the CONFIG MODE (page 12). Use the down key to access cooking profiles 5-8.

Press the up and down keys to also change option settings, where applicable.

### 4. Back/Off Key

Depending on the mode the oven is in, the back/off key will return the oven to the previous screen or turn the oven off.

### 5. Idle Key

The idle key immediately activates the IDLE MODE (page 9).

### 6. Emergency Stop Key

The emergency stop key shuts down the conveyor and burner and the display shows the belts halted screen. From the belts halted screen, press the back/off key to turn the conveyor back on and send the oven to the COOLING DOWN MODE (page 9).

DO NOT use the emergency stop key as a general on/off switch.

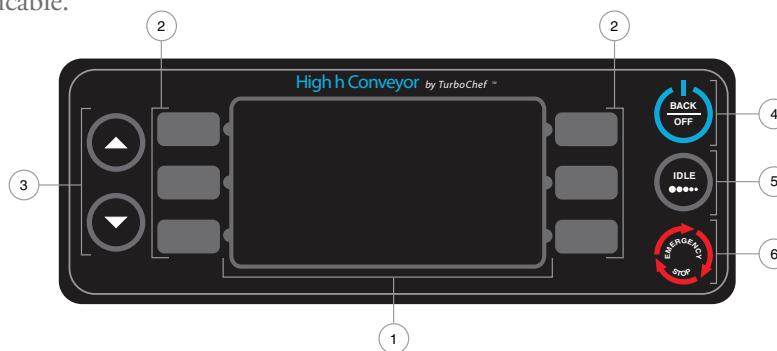

Figure 4: Oven Controls

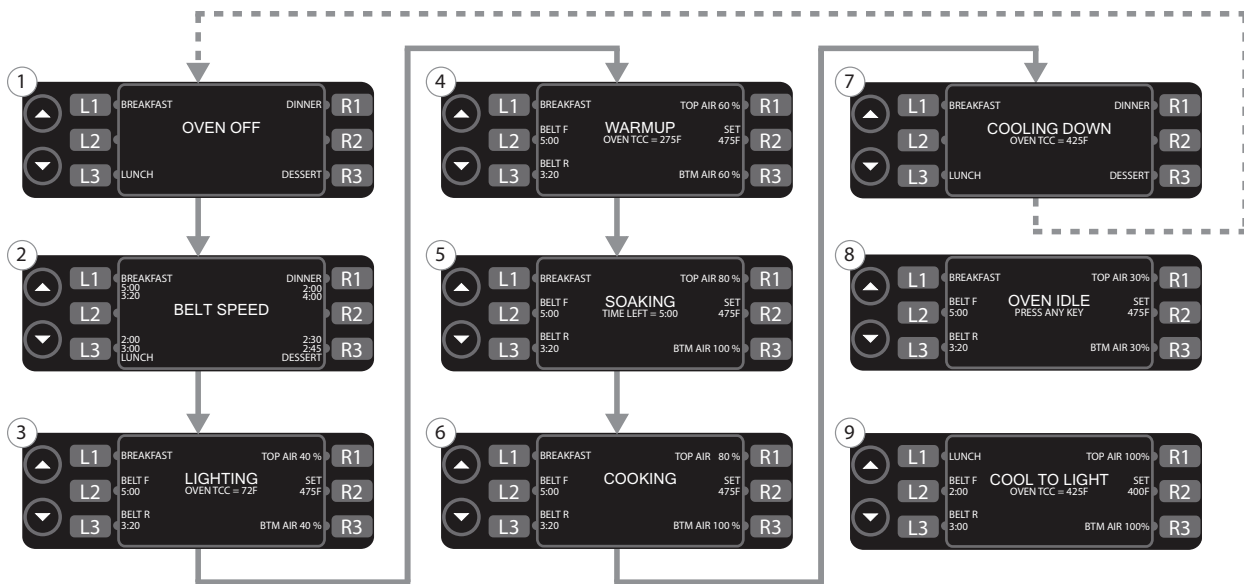

Figure 5: Cooking Modes

## Cooking a Product

Figure 5

This section explains how to cook a food product by describing the “standard operation” modes through which the oven progresses.

- MODE 1: Oven Off
- MODE 2: Belt Speed Select
- MODE 3: Lighting
- MODE 4: Warmup
- MODE 5: Soaking
- MODE 6: Cooking
- MODE 7: Cooling Down
- MODE 8: Idle
- MODE 9: Cool To Light

NOTE: MODES 8 and 9 are not part of a “standard” cooking cycle. They only occur when the user intervenes as described on page 9.

### Mode 1: Oven Off

Mode during which all cooking components are off and the oven temperature has receded below 150°F (66°C), but the display and keypad remain on. The user can access cooking profiles 1-4 on this screen or press the down key to access cooking profiles 5-8.

Happens When...

- Power is supplied to the oven.
- The oven completes MODE 7.

-The user presses the down key while accessing the CONFIG MODE (refer to page 12 for more information).

Goes To...

- MODE 2 when the user selects a cooking profile (soft keys L1, L3, R1, or R3).
- CONFIG MODE when the user presses the up key.

### Mode 2: Belt Speed Select

Mode during which the user selects the desired belt speed.

NOTE: If a different key is pressed, the oven will ask if you wish to continue or return to the belt speed select screen. If you select continue, the oven will not save the belt speed.

Happens When...

- The user selects a cooking profile from MODE 1 or 7.

Goes To...

- MODE 3 when the user selects a belt speed and the set cooking temperature is higher than the oven’s current temperature.
- MODE 9 when the user selects a belt speed and the set cooking temperature is lower than the oven’s current temperature.

### Mode 3: Lighting

Mode during which the ignition module applies voltage to the spark rod to start the burner.

**Happens When...**

- The user selects a belt speed from MODE 2.

**Goes To...**

- MODE 4 when the I/O control board receives a signal from the flame sensor that a flame is present.
- MODE 6 if the oven's current temperature is within 25°F (14°C) of the oven's set temperature.

**Mode 4: Warmup**

Mode during which the oven warms to the preset cooking temperature defined by the cooking profile that was selected.

**Happens When...**

- MODE 3 successfully completes, and the oven's temperature at the beginning of the warmup was not within (less than) 25°F (14°C) of the oven's set temperature.

**Goes To...**

- MODE 5 once the oven has reached the temperature defined by the selected cooking profile.
- MODE 7 when the user presses the back/off key and the oven is above 150°F (66°C).

**Mode 5: Soaking**

Mode during which the oven has completed warming up and automatically allows an additional five minutes for the oven cavity surfaces to warm.

**Happens When...**

- MODE 4 completes (within 5°F [3°C] of set point).

**Goes To...**

- MODE 6 when soaking completes.
- MODE 7 when the user presses the back/off key and the oven is above 150°F (66°C).

**Mode 6: Cooking**

Mode during which the oven is ready to cook. The user can place food on the conveyor to cook, or edit cook settings if the full edit or flex option is enabled. See pages 10-11 for more information on full edit and flex options.

**Happens When...**

- MODE 5 completes.
- MODE 3 completes, if the oven's current temperature is within 25°F (14°C) of the oven's set temperature.

- The user presses the idle key, up key, down key, or any soft key during MODE 8.

**Goes To...**

- MODE 7 when the user presses the back/off key.
- MODE 8 when the user presses the idle key.
- MODE 4 if the temperature drops 25°F (14°C) or more below the set point.
- MODE 9 if temperature rises 25°F (14°C) or more above the set point.

**Mode 7: Cooling Down**

Mode during which the burner assembly shuts off to allow the oven to cool.

**Happens When...**

- The user presses the back/off key from modes 3 or 4 (and the oven temperature is above 150°F [66°C]), or from modes 5, 6, 8, or 9.

**Goes To...**

- MODE 1 when the oven temperature has receded below 150°F (66°C).
- MODE 2 when the user selects a cooking profile.

**Mode 8: Idle**

Mode during which both blowers are reduced to 30% to save power. All other oven components remain the same.

**Happens When...**

- The user presses the idle key from MODE 6.

**Goes To...**

- MODE 6 when the user presses the idle key, up key, down key, or any soft key.
- MODE 7 when the user presses the back/off key.

**Mode 9: Cool To Light**

Mode during which the burner assembly shuts off to allow the oven to cool to the set cooking temperature defined by the profile that was selected.

**Happens When...**

- The user selects a cooking profile from MODE 1 or 7 that has a set cooking temperature lower than the oven's current temperature.

**Goes To...**

- MODE 3 when the oven has cooled to the set temperature of the current cooking profile.
- MODE 7 when the user presses the back/off key.

## Editing a Cooking Profile

To edit a cooking profile, the oven must be in the cooking mode and the full edit or flex option must be enabled. For more information on selecting between full edit, rigid, and flex options, see Edit Options Screen on page 13.

When the **rigid option** is enabled, the soft keys displayed in fig. 6 are disabled and no menu editing is allowed.

When the **full edit option** is enabled, a cooking profile is fully customizable and all changes are saved once the oven returns to the OVEN OFF MODE.

When the **flex option** is enabled, a cooking profile is customizable within flex option limitations (as described in the following sections), and all changes will reset when the oven returns to the OVEN OFF MODE.

This section assumes that the full edit option is enabled (except where otherwise noted) and that a cooking profile has been enabled.

## Changing a Cooking Profile's Name

The full edit option must be enabled to change a cooking profile's name.

1. Press L1 (fig. 6) to access the name change screen (fig. 7).
2. Change the name of the cooking profile.
  - The up key moves up through the available characters. e.g. A,B,C...
  - The down key moves down through the available characters e.g. A,+,-, ,9,8,...
  - INS (L1) inserts a space.
  - DEL (R1) deletes the selected character.

- ---> (R2) moves the cursor to the right. The cursor starts at the far left character. If ---> is pressed when the cursor is on the far right character, the cursor moves to the far left character.

- <--- (L2) moves the cursor to the left. The cursor starts at the far left character. If <--- is pressed when the cursor is on the far left character, the cursor moves to the far right character.

3. Press save (R3) to save the changes or cancel (L3) to cancel any changes.

## Adjusting the Belt Speed

Figure 6

The High h Conveyor Oven can accommodate either one or two conveyor belts. The oven will automatically detect the number of conveyor belts installed and display the option to change the speed of each conveyor belt independently.

1. Press the soft key adjacent to the conveyor belt you wish to adjust (press L2 for the front belt [Belt F] or L3 for the rear belt [Belt R]).
2. Adjust the time it takes for the conveyor belt to completely cycle through the oven.
  - The up key increases bake time in 5-second increments.
    - +Flex option enabled: the user can only increase the time up to an additional 15 seconds.
  - The down key decreases bake time in 5 second increments.
    - +Flex option enabled: the user cannot decrease the time by more than 15 seconds.
3. Press the soft key adjacent to the belt that was adjusted to exit the belt speed controls.

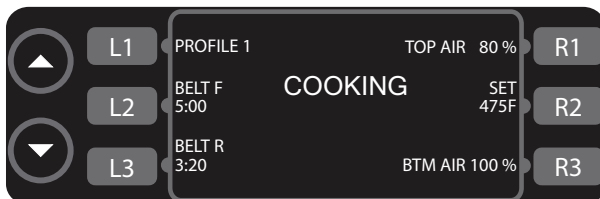

Figure 6: Cooking Screen

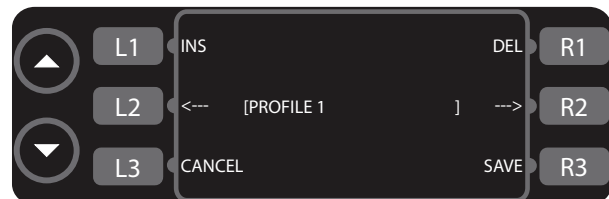

Figure 7: Name Change Screen

## Adjusting the Temperature

Figure 6

1. Press R2 to access the temperature controls.
2. Adjust the temperature.
  - Press the up key to increase the temperature in 5°F/5°C increments.
    - +Flex option enabled: the user can only increase the temperature up to an additional 10°F/5°C.
  - Press the down key to decrease the temperature in 5°F/5°C increments.
    - +Flex option enabled: the user cannot decrease the temperature by more than 10°F/5°C.
3. Press R2 again to exit the temperature controls.

## Adjusting the Top and Bottom Air

Figure 6

1. Press R1 to access the top air controls, or R3 to access the bottom air controls.
2. Adjust the air speed.
  - Press the up key to increase the air speed in 5% increments up to 100%.
    - +Flex option enabled: the user can only increase the air speed by up to an additional 15%.
  - Press the down key to decrease the air speed in 5% increments down to 30%.
    - +Flex option enabled: the user cannot decrease the air speed by more than 15%.
  - Press the soft key again to exit the air controls.

## Config Mode

Figure 8

The CONFIG MODE provides access to:

1. Smart card screen
2. Fault count screen
3. SETUP MODE
4. TEST MODE

To access the CONFIG MODE, press the up key from the OVEN OFF or COOLING DOWN MODE.

## Smart Card Screen

The smart card screen allows the user to:

- Load a menu from smart card to oven.
- Save a menu from oven to smart card.

To load or save a menu,

1. Insert a smart card chip-first into the smart card slot (fig. 10) with the chip facing the inside of the oven.
2. Press L3 (fig. 8) to access the smart card screen (fig. 11).

NOTE: If no smart card is inserted or is inserted incorrectly, fig. 9 will appear.

3. Load or save a menu:
  - Press R1 to load a menu from the smart card to the oven (fig. 11).

**CAUTION:** Pressing R1 will permanently erase the previous cooking profiles and settings on the oven.

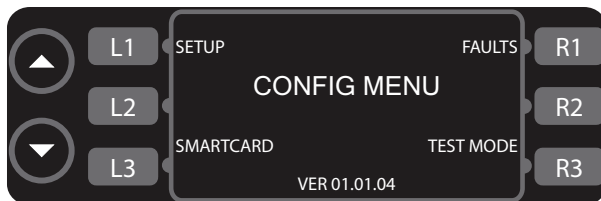

Figure 8: Config Mode



Figure 9: Insert Smart Card Screen

-Press R2 to save a menu from the oven to the smart card (fig. 11).

**CAUTION:** Pressing R2 will permanently erase the previous profiles and settings on the smart card.

## Fault Count Screen

From the CONFIG MODE (fig. 8), press R1 to access the fault count screen (fig. 12). See Troubleshooting (page 14) for more information on fault codes.

## Test Mode

TEST MODE is for service use only.

## Setup Mode

Figure 13

The SETUP MODE serves four main purposes:

1. To change the temperature measurement setting (°F or °C).
2. To access the edit option screen.
3. To change the display language.
4. To access the info screen.

To access the SETUP MODE, press the L1 soft key from the CONFIG MODE (fig. 8).

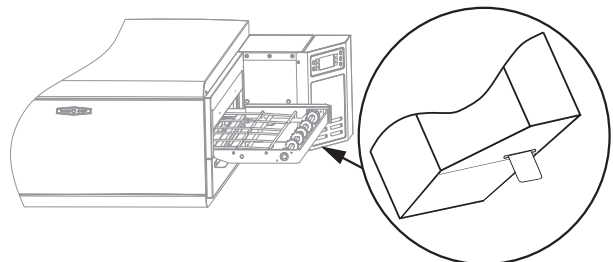

Figure 10: Smart Card Slot Location

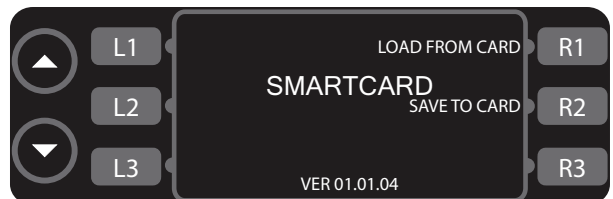

Figure 11: Smart Card Screen

## Changing the Temperature Measurement Setting

The oven can display the temperature in either Celsius or Fahrenheit. To change the setting, press L1 in the SETUP MODE (fig. 13).

## Edit Option Screen

The edit option screen allows the user to switch between full edit, rigid, and flex. For more information on the different edit options, see Editing a Cooking Profile on page 10.

To access the edit option screen,

1. Press L3 (fig. 13) to access the password screen (fig. 14).
2. Input the password 6 6 3 3 by pressing the soft key adjacent to the appropriate number.

To change the edit option (fig. 15),

- Press L1 to select full edit.
- Press L2 to select rigid.
- Press L3 to select flex.

NOTE: an ‘\*’ will appear next to the selected edit option.

## Changing the Language

Figure 13

The oven is programmed to display four languages:

- English
- French
- German
- Spanish

Press R1 to change the language.

NOTE: This feature is not available on all models.

## Info Screen

Figure 16

The info screen is used to display the following information:

- Serial number
- Electrical compartment temperature
- Incoming voltage
- Total time the oven has been on
- Total time the oven has been idle
- Software version

To access the info screen, press R3 within the SETUP MODE (fig. 13).

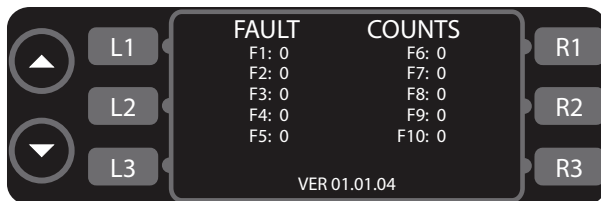

Figure 12: Fault Counts Screen

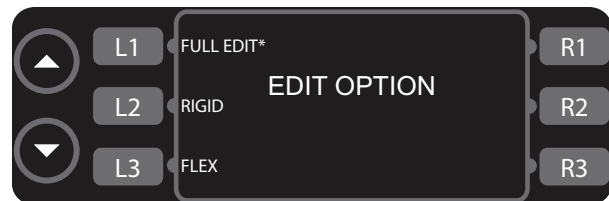

Figure 15: Edit Option Screen



Figure 13: Setup Mode

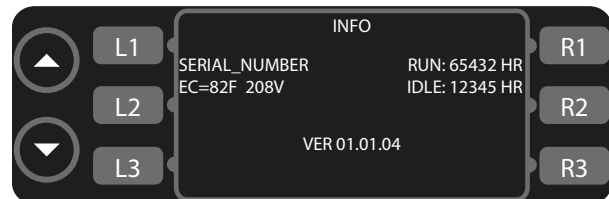

Figure 16: The Info Screen

## Troubleshooting

The following is a list of fault codes and possible problem(s) that the oven may be experiencing. Please attempt the recommended action before calling Customer Service (800.90TURBO, +1 214-379-6000) or your Authorized Distributor.

Issue	Possible Cause(s)	Resolution
No power to oven.	<ul style="list-style-type: none"> <li>- Oven is not plugged in.</li> <li>- Main circuit breaker is tripped.</li> </ul>	<ul style="list-style-type: none"> <li>- Plug oven in.</li> <li>- Verify wall circuit breaker is on. Reset breaker and then power oven back on.</li> </ul>
Oven is not warming up properly.	<ul style="list-style-type: none"> <li>- Oven is in the off state.</li> <li>- Oven has been switched off at the main circuit breaker.</li> <li>- Problem with the gas supply.</li> </ul>	<ul style="list-style-type: none"> <li>- Select a cooking profile.</li> <li>- Press the back/off key until the oven is in the off state – leave for two minutes. Unplug the oven – leave for two minutes. Re-plug in the oven, switch on the isolator/main power supply and select a cooking profile.</li> <li>- Turn the oven off and ensure the flex hose is firmly attached. Call customer service</li> </ul>
Oven is not cooking properly	<ul style="list-style-type: none"> <li>- Oven is not clean.</li> <li>- Incorrect cooking profile was selected for the product.</li> <li>- Product was not cooked from correct starting state, e.g. chilled or frozen.</li> </ul>	<ul style="list-style-type: none"> <li>- Clean the oven following the deep-cleaning instructions on page 5-6.</li> <li>- Ensure that the correct cooking profile is selected for the product.</li> <li>- Ensure product is in the correct state before being placed in the oven.</li> </ul>
F1: Blower Failure	<ul style="list-style-type: none"> <li>- Oven power interrupted.</li> </ul>	<ul style="list-style-type: none"> <li>- Verify wall circuit breaker is on. Reset breaker and then power the oven back on. Press the back/off key until the oven is in the off mode – leave for two minutes. Unplug the oven – leave for two minutes. Re-plug in the oven, switch on the isolator/main power supply and select a cooking profile.</li> </ul>
F2: Low Temp During Cook	<ul style="list-style-type: none"> <li>- Oven power interrupted.</li> <li>- Oven is not clean.</li> <li>- Oven not fully warmed up.</li> <li>- Defective burner.</li> <li>- Blower motor not running.</li> </ul>	<ul style="list-style-type: none"> <li>- Verify wall circuit breaker is on. Reset breaker and then power oven back on.</li> <li>- Clean the oven following the deep-cleaning instructions on page 5-6.</li> <li>- Press the back/off key until oven returns to the OVEN OFF MODE. Re-select the cooking profile and allow oven to reheat.</li> <li>- Call customer service.</li> <li>- Call customer service.</li> </ul>

Issue	Possible Cause(s)	Resolution
F3: Flameout	<ul style="list-style-type: none"> <li>- Oven power interrupted.</li> <li>- Damaged or defective oven components.</li> <li>- Inlet gas pressure is low or off.</li> </ul>	<ul style="list-style-type: none"> <li>- Verify wall circuit breaker is on. Reset breaker and then power oven back on.</li> <li>- Call customer service.</li> <li>- Call customer service.</li> </ul>
F5: CC Over Temp	<ul style="list-style-type: none"> <li>- Blockage of airflow into the oven.</li> <li>- Problem with the blower motors or burner.</li> </ul>	<ul style="list-style-type: none"> <li>- Check for and remove anything that may be obstructing regular airflow into the oven.</li> <li>- Call customer service.</li> </ul>
F6: EC Over Temp	<ul style="list-style-type: none"> <li>- Blockage of airflow into the electrical compartment.</li> <li>- Problem with the cooling fans.</li> </ul>	<ul style="list-style-type: none"> <li>- Check for paper towels or anything that may be obstructing cool air into the electrical compartment.</li> <li>- Call customer service.</li> </ul>
F7: RTD Failure	<ul style="list-style-type: none"> <li>- Damaged or defective oven components.</li> </ul>	<ul style="list-style-type: none"> <li>- Call customer service.</li> </ul>
F8: High Limit Tripped		<ul style="list-style-type: none"> <li>- Call customer service.</li> </ul>
F9: Belt Run Failure	<ul style="list-style-type: none"> <li>- Too much weight on belt.</li> <li>- Obstruction blocking belt rotation.</li> <li>- Damaged or defective oven components.</li> </ul>	<ul style="list-style-type: none"> <li>- Ensure oven is in the off state and completely cooled and belt is completely stopped. If belt is overloaded, remove product from belt.</li> <li>- Ensure oven is in the off state and completely cooled and belt is completely stopped. Look into oven cavity and remove any obstructions that are blocking the belt's rotation.</li> <li>- Call customer service.</li> </ul>
F10: Air Switch Fault	<ul style="list-style-type: none"> <li>- Damaged or defective oven components.</li> </ul>	<ul style="list-style-type: none"> <li>- Call customer service.</li> </ul>

## Replaceable Parts

The following is a list of parts that may need replacing during the life of the oven. For more information, please contact TurboChef. (Within North America, call 800.90TURBO. Outside North America, call +1 214.379.6000 or your authorized distributor.)

Description	Part Number
Air Pressure Switch	102836
Blower Motor	HHC-6520
Blower Motor Controller (BMSC)	103580
Burner Assembly	HHC-6468
Combustion Motor (90°)	103620
Combustion Motor (Inline)	103656
Combustion Motor Controller (90°, Nat Gas)	HHC-6630-3
Combustion Motor Controller (Inline, Nat Gas)	HHC-6630-4
Combustion Motor Controller (90°, Propane)	HHC-6630-5
Combustion Motor Controller (Inline, Propane)	HHC-6630-6
Control Board	CON-7002
Cooling Fan	100083
Display	100505
EMI Filter	100542
Filter, Air, Front, 11.75" x 7.5"	HHC-6017
Filter, Air, Rear, 9" x 3.25"	HHC-6343

Description	Part Number
Flame Sensor	103624
Fuse	100599
Gas Valve, Modulating	102832
Gear Drive, Dual Belt	HHC-4120
Gear Drive, Single Belt	HHC-6538
Gear Drive Controller (Dual Drive)	HHC-6630-2
Gear Drive Controller (Single Drive)	HHC-6630-1
Ignition Module	103626
Keypad	HHC-1234
Power Supply, Domestic	HHC-6501
Power Supply, International	101211
Relay, K3, 24 VDC, 20A	101274
Relay, K4, Sealed, 24 VAC, 20A	101275
RTD Probe	HHC-6517
Smart Card Reader	100506
Spark Assembly	103623
Speaker	104155
Thermostat, 120F, Close on Rise	102086
Thermostat, High Limit	102075

# North America Limited Warranty

## TURBOCHEF “HhC 3240” CONVEYOR OVEN - NORTH AMERICA

The TurboChef HhC 3240 Conveyor Oven limited warranty outlined below is activated when the Factory Start Up that is included with all gas ovens is performed. Should you require additional assistance after reviewing the limited warranty outlined below, please call TurboChef Customer Service at 800.90TURBO.

### LIMITED WARRANTY

TurboChef Technologies, Inc. (“TurboChef”) warrants to you, the purchaser, that under normal use, the TurboChef HhC 3240 Conveyor Oven you have purchased (the “Equipment”) will be free from defects in material and workmanship during the Warranty Period, subject to the terms and conditions set forth herein. The “Warranty Period” is twelve (12) months from the date the Factory Start Up that is included with all gas ovens is performed. This limited warranty is conditioned upon you promptly notifying TurboChef of any claims, as provided in the paragraph entitled “Warranty Claims” below, and providing TurboChef with all data and information requested by TurboChef or its service agents in connection with such claims as well as all necessary access to your premises and the Equipment. This limited warranty is made only to the initial purchaser of the Equipment from TurboChef or its authorized dealer; it is not assignable to subsequent purchasers unless TurboChef consents to such assignment in writing.

### DISCLAIMER OF WARRANTIES

**EXCEPT AS PROVIDED IN THE LIMITED WARRANTY ABOVE, THE EQUIPMENT IS PROVIDED “AS IS”. THERE ARE NO WARRANTIES, EXPRESS, IMPLIED OR STATUTORY, WHICH EXTEND BEYOND THE DESCRIPTION ON THE FACE HEREOF INCLUDING ANY IMPLIED WARRANTY OF MERCHANTABILITY AND/OR FITNESS FOR A PARTICULAR PURPOSE AND/OR ANY IMPLIED WARRANTY OF NON-INFRINGEMENT. THIS LIMITED WARRANTY GIVES YOU SPECIFIC LEGAL RIGHTS WHICH MAY VARY DEPENDING UPON THE LAW OF YOUR STATE OR COUNTRY.**

### WARRANTY EXCLUSIONS

**Improper Installation, Operation or Maintenance:** Equipment that is not installed, operated and maintained in accordance with TurboChef’s HhC 3240 Conveyor Oven owner’s and installation manual (as may be updated by TurboChef from time to time, the “Manual”), copies of which are provided to you with the Equipment or otherwise will be provided to you upon request, is excluded from this limited warranty. This limited warranty shall not apply to damage which results, in TurboChef’s or its service agent’s sole opinion, due to any of the following causes: failure to provide a suitable installation and operating environment (including power and HVAC) and facilities as prescribed by the Manual; misuse; abuse; accident; neglect; power failure; power surges (over or under voltage); flood; fire; lightning or other natural or man-made disasters or other Acts of God. This limited warranty shall not apply to Equipment that has missing or altered serial numbers.

**Modifications and Repair:** Equipment that has been modified or altered by persons other than TurboChef or its service agents, or Equipment that has had non-approved devices or connection items attached thereto, is excluded from coverage under this limited warranty. Repair of the Equipment by anyone other than TurboChef or its authorized service agents will void all warranties on the Equipment.

Accessories: Accessories and parts (collectively “Accessories”) that are consumed in the normal course of equipment operation or maintenance are excluded from this limited warranty. Failure of or damage to Equipment or components from the use of non-approved cleaning chemicals, devices or processes is also excluded from this limited warranty.

Outstanding Invoices: If the full invoiced amount for Equipment purchased has not been paid within forty-five (45) days from the invoice date, then TurboChef will have no obligation to honor this or any other warranty on the Equipment until payment is received in full, and any accrued interest or other charges have been satisfied, at which time warranty coverage will be reinstated, but the Warranty Period will not be extended.

## **WARRANTY SERVICE; EXCLUSIVE REMEDY**

TurboChef will be solely responsible for determining whether or not the Equipment or any component thereof is defective. Defective components covered by this limited warranty will be repaired or replaced at TurboChef’s option without charge to you and such repaired or replacement components will be covered by this limited warranty for the balance of the Warranty Period. Parts used in the repair of defective components and replacement components may be new, recovered or rebuilt. At its sole option, TurboChef may decide to replace defective Equipment covered by this limited warranty with new, recovered or rebuilt Equipment of equal or greater capability, and such Equipment will be covered by this limited warranty for the balance of the Warranty Period. Defective Equipment and components will become the property of TurboChef. This paragraph states TurboChef’s sole and exclusive obligation and liability and your sole and exclusive remedy under this limited warranty. TurboChef shall not be responsible for a failure to provide warranty services due to causes beyond TurboChef’s or its service agents’ control.

## **WARRANTY CLAIMS**

Claims under this limited warranty must be reported to TurboChef during our normal working hours at the following number: 800.90TURBO, or such other reporting service as TurboChef may designate. Upon receipt of the claim and related information and preliminary verification that the claim is valid, TurboChef will promptly notify an authorized service agent to contact you and arrange for an on-site repair visit during the service agent’s normal working hours. Any costs incurred by TurboChef or its service agent associated with a service agent being refused or unable to gain access to the Equipment on your premises, or a claim not covered by this limited warranty, will be charged to you.

## **CHARGES FOR NON-WARRANTY SERVICE OR REJECTION OF SERVICE VISIT**

In the event that repairs, replacement or service are provided by TurboChef’s service agents for work not covered by this limited warranty, customer agrees to pay the service agent directly according to the service agent’s normal scale of charges. In the event TurboChef is invoiced by the service agent for services not covered under this limited warranty, TurboChef will invoice customer and customer will pay such invoice based on terms of net 10 days. Customer also agrees to pay any cost incurred by TurboChef or its service agent associated with a service agent responding to a call for service, but then being refused or unable to gain access to the Oven on Customer’s premises. Failure to submit payment may, at TurboChef’s discretion, result in TurboChef voiding the balance of the warranty. In no event will TurboChef authorize service to a store with an outstanding Non-Warranty invoice.

## DISCLAIMER OF DAMAGES

TURBOCHEF DISCLAIMS ALL INCIDENTAL, SPECIAL AND CONSEQUENTIAL DAMAGES, INCLUDING BUT NOT LIMITED TO, LOSS OF USE, LOST REVENUE OR PROFITS, OR SUBSTITUTE USE, SUFFERED BY YOU OR ANY THIRD PARTY, WHETHER ARISING IN CONTRACT, TORT (INCLUDING NEGLIGENCE), OR OTHERWISE, RESULTING FROM ANY BREACH BY TURBOCHEF OR ITS SERVICE AGENTS OF THIS LIMITED WARRANTY, OR RESULTING FROM THE MANUFACTURE, USE, OR DEFECTS, OF OR IN THE EQUIPMENT, EVEN IF TURBOCHEF WAS APPRISED OF THE POSSIBILITY OF SUCH DAMAGES. SOME STATES AND COUNTRIES DO NOT ALLOW THE EXCLUSION OF INCIDENTAL OR CONSEQUENTIAL DAMAGES, SO THE ABOVE LIMITATION MAY NOT APPLY TO YOU.

## CUSTOMER INDEMNITY

You agree to indemnify, defend and hold TurboChef harmless from all third party claims, demands, judgments, fees and costs directly or indirectly arising out of or related to your improper use of the Equipment. You further agree to indemnify and hold TurboChef harmless from any incidental, consequential or special damages suffered by you, including lost revenue or profits, loss of use, or substitute use, during periods of Equipment failure or loss of use.

## TERRITORY

This limited warranty is valid in the United States of America, Canada and Puerto Rico.

## Waiver

Waiver by TurboChef of any default will not be deemed a continuing waiver of such default or a waiver of any other default.

## GOVERNING LAW, ENTIRE WARRANTY

This limited warranty shall be governed and construed in accordance with the laws of the State of Georgia, USA (except with respect to its provisions regarding conflicts of laws). The limited warranty described herein is the complete and only warranty for Equipment and supersedes all prior oral or written agreements and understandings that may have existed between us relating to Equipment warranties. The terms of this limited warranty may not be altered, amended or modified except by a signed writing from TurboChef. Any purported alteration, amendment or modification by a service agent or anyone else will not be enforceable against TurboChef.

# International Limited Warranty

## TURBOCHEF HhC 3240 CONVEYOR OVEN - INTERNATIONAL

This limited warranty shall apply to the sales of all TurboChef HhC 3240 Conveyor Ovens (the “Equipment”) manufactured by TurboChef Technologies, Inc. (“TurboChef”), and sold to purchasers outside of the United States, Canada and Puerto Rico by an Authorized Distributor of TurboChef International (the “Authorized Distributor”).

### LIMITED WARRANTY

You, the purchaser (“You”) have entered into a sales contract with the Authorized Distributor for the purchase of the Equipment. This limited warranty is made to you by the Authorized Distributor from whom you purchased the Equipment with the support of TurboChef. Subject to the limitations stated below, the Authorized Distributor warrants to You that the quantity and specification of the Equipment delivered to You shall be as set out in the Authorized Distributor’s acceptance of your order and that the Equipment will be free from any material defects in the product and workmanship for twelve (12) months from the date the Factory Start Up that is included with all gas ovens is performed (the “Warranty Period”), subject to the terms and conditions set forth herein.

### DISCLAIMER

**EXCEPT AS PROVIDED IN THE LIMITED WARRANTY ABOVE, THE EQUIPMENT IS PROVIDED “AS IS”. THERE ARE NO WARRANTIES, EXPRESS, IMPLIED, COMMON LAW OR STATUTORY, WHICH EXTEND BEYOND THE DESCRIPTION ON THE FACE HEREOF INCLUDING ANY IMPLIED WARRANTY OF MERCHANTABILITY AND/OR FITNESS FOR A PARTICULAR PURPOSE AND/OR ANY IMPLIED WARRANTY OF NON-INFRINGEMENT. THIS LIMITED WARRANTY GIVES YOU SPECIFIC LEGAL RIGHTS WHICH MAY VARY DEPENDING UPON THE LAW OF YOUR STATE OR COUNTRY.**

### THE TURBOCHEF GLOBAL WARRANTY SYSTEM

This limited warranty commences upon delivery of the Equipment to Your premises. The Authorized Distributor will inspect and install the Equipment at Your premises in accordance with TurboChef’s instructions and will record the serial number of the Equipment, Your contact details, the date and location of installation and the results of the Authorized Distributor’s inspection. This information will be entered by the Authorized Distributor into the TurboChef global warranty system and will be used by TurboChef, the Authorized Distributor and its authorized service agents for the provision of the warranty service.

### WARRANTY SERVICE

During the Warranty Period, any materially defective Equipment will be repaired or replaced free of charge at TurboChef’s option provided that:

1. You notify the Authorized Distributor from whom You purchased the Equipment and/or TurboChef as soon as reasonably possible after discovery of a defect and in accordance with the warranty claims procedure set out below;

2. You provide the Authorized Distributor from whom You purchased the Equipment and/or TurboChef with all data and information reasonably requested by TurboChef, the Authorized Distributor or its authorized service agents in connection with Your warranty claim;
3. You make the Equipment available to TurboChef, the Authorized Distributor or its authorized service agents;
4. The Equipment has been installed by an Authorized Distributor and you have provided all necessary information for the Authorized Distributor to register the Equipment in the TurboChef global warranty system;
5. The Equipment has been operated and maintained by You in accordance with TurboChef's "Owner's Manual" provided with the Equipment (and as updated by TurboChef);
6. You have not used any non-approved devices, accessories, consumables or parts in conjunction with the Equipment; and
7. Repairs, modifications or alterations have not been attempted other than by TurboChef, an Authorized Distributor or its authorized service agent.

Neither TurboChef nor the Authorized Distributor assumes any liability for damage caused, in TurboChef's, its Authorized Distributor's or its service agent's sole opinion, by any of the following: Your failure to provide a suitable installation and operating environment (including power and HVAC) or facilities as prescribed by the Manual; misuse or abuse; accident; neglect; power failure or power surges (over or under voltage); Acts of God; lightning, floods, or other natural disaster; or any man-made disaster. This limited warranty shall not apply to Equipment that has missing or altered serial numbers.

At its sole option, TurboChef may replace defective Equipment or components with new, recovered or rebuilt Equipment of equal or greater capability, and such Equipment or components will be warranted by the Authorized Distributor for the balance of the Warranty Period. Replaced defective Equipment or components will become the property of TurboChef.

**Warranty Claims:** Any warranty claim must be made directly in writing either to the Authorized Distributor from whom You purchased the Equipment or to TurboChef at the following address:

TurboChef Technologies, Inc.  
 4240 International Parkway, Suite 105  
 Carrollton, Texas 75007  
 Phone: +1 214-379-6000  
 Fax: +1 214-379-6073

The claim must include the serial number of the Equipment and be received by TurboChef on or before the last day of the Warranty Period. Upon receipt of Your claim, TurboChef will promptly notify an Authorized Distributor or an authorized service agent to contact You, to verify Your claim and, if necessary, to arrange for an on-site repair visit during normal working hours.

**Consumables and Parts Used with The Equipment:** Neither TurboChef nor the Authorized Distributor assumes any liability for consumables and parts that are used in the normal course of Equipment operation or for failure of or damage to Equipment or components from the use of non-approved cleaning chemicals, devices or processes.

**Charges for Service Not Covered by Limited Warranty:** In the event that You request and receive repairs, replacement or service not covered by this limited warranty, You will be invoiced and must pay the Authorized Distributor or authorized service agent directly according to its normal scale of charges and business terms.

**Product Liability:**

**NEITHER TURBOCHEF NOR THE AUTHORIZED DISTRIBUTOR ASSUMES ANY LIABILITY FOR ANY INCIDENTAL, SPECIAL OR CONSEQUENTIAL DAMAGES, INCLUDING BUT NOT LIMITED TO LOSS OF USE, LOST REVENUE OR PROFITS, OR SUBSTITUTE USE SUFFERED BY YOU OR ANY THIRD PARTY, WHETHER ARISING IN CONTRACT, TORT (INCLUDING NEGLIGENCE), OR OTHERWISE RESULTING FROM ANY BREACH BY TURBOCHEF OR THE AUTHORIZED DISTRIBUTOR OF THE LIMITED WARRANTY PROVIDED HEREIN, EVEN IF TURBOCHEF AND/OR THE AUTHORIZED DISTRIBUTOR WERE APPRISED OF THE POSSIBILITY OF SUCH DAMAGES. THIS LIMITED WARRANTY GIVES YOU SPECIFIC LEGAL RIGHTS, AND YOU MAY ALSO HAVE OTHER RIGHTS THAT VARY FROM COUNTRY TO COUNTRY. SOME COUNTRIES MAY NOT ALLOW THE EXCLUSION OR LIMITATION OF INCIDENTAL OR CONSEQUENTIAL DAMAGES, MAY NOT ALLOW LIMITATIONS ON HOW LONG AN IMPLIED WARRANTY OR CONDITION LASTS, OR ALLOW PROVISIONS THAT PERMIT THE WARRANTY TO BE VOIDED. THUS, SOME OF THE ABOVE LIMITATIONS OR EXCLUSIONS MAY NOT APPLY TO YOU.**

**Exclusive Remedy:** This limited warranty states the Authorized Distributors and TurboChef's sole and exclusive obligation and liability and your sole and exclusive remedy under this limited warranty.

**Third Party Rights:** The UK Contract (Rights of Third Parties) Act 1999 is excluded from applying to this limited warranty and nothing herein confers or purports to confer on any third party any benefit or any right to enforce any term of this limited warranty.

## Waiver

Waiver by TurboChef or an Authorized Distributor of any default will not be deemed a continuing waiver of such default or a waiver of any other default.

**Severability:** If any item or provision contained in this limited warranty or any part of them ("an offending provision") is declared to be or becomes unenforceable, invalid or illegal for any reason whatsoever in any jurisdiction, the other terms and provisions of this limited warranty shall remain in full force and effect in that jurisdiction as if it had been executed without the offending provision appearing in it and the entire limited warranty shall remain in full force and effect in all other jurisdictions.

**Governing Law, Entire, Agreement:** This limited warranty shall be governed by and construed according to English law. The application of the United Nations Convention on International Sale of Goods to this limited warranty is expressly excluded. This limited warranty may not be altered, amended or modified by the Authorized Distributor or its service agent, and no representation, alteration, amendment or modification by TurboChef shall be valid unless in a signed form from TurboChef.



*For service or information:*

Within North America call  
**800.90TURBO**

Outside North America call  
**+1 214.379.6000** or  
**Your Authorized Distributor**



*Accelerating the World of Cooking™*

Part Number: HHC-6650 / Rev. C / May 2008  
Country Code: NA/EU

*Corporate Headquarters*

Six Concourse Parkway, Suite 1900  
Atlanta, Georgia 30328 USA  
+1 678.987.1700 PHONE  
+1 678.987.1750 FAX

*Global Operations*

4240 International Pkwy, Suite 105  
Carrollton, Texas 75007 USA  
+1 214.379.6000 PHONE  
+1 214.379.6073 FAX

*Customer Service:* 800.90TURBO  
+1 214.379.6000

turbochef.com