



Accelerating the World of Cooking™

Owner's Manual

FOR THE TURBOCHEF i5 RAPID COOK OVEN



For further information, call

800.90TURBO

or

+1 214.379.6000

The information contained in this manual is important for the proper installation, use, maintenance, and repair of this oven. Follow these procedures and instructions to help ensure satisfactory baking results and years of trouble-free service.

Errors – descriptive, typographic, or pictorial – are subject to correction. Specifications are subject to change without notice.

Please carefully read this manual and retain it for future reference.

Table of Contents

Safety Instructions

General Safety Information	i
Reducing Fire Risk	i
Grounding Instructions	ii
Power Cord Replacement	ii
Precautions to Avoid Possible Exposure to Excessive Microwave Energy	ii
RF Interference Considerations	ii

General Oven Information

Theory of Operation	1
Certifications	1
Dimensions	1
Oven Construction	1
Electrical Specifications	2

Installation

Unpacking Instructions	3
Lifting and Placing the Oven	3
Installation Near Open Heat Source	4
Optional Installation Items	4
Voltage Selection	4

Daily Maintenance

Daily Cleaning	6
Supplies and Equipment	6

Oven Controls

8

Cooking

Oven Off	9
Temperature Select	10
Warming Up	10
Soak	10
Ready to Cook (or “Idle”)	10
Adjust Time	10
Cooking	11
Remove Food from Oven	11
Cook More	11
Cooling Down	11

The Info Mode

Overview of the Info Mode	12
Viewing Cook Counts/Time Logs	12
Viewing the Fault Log	12
Viewing the Service Numbers	13
Resetting the Oven	13
Setting the Date/Time	13
Turning Oven Options On/Off	13
Loading a Menu	14

The Edit Mode

Overview of the Edit Mode	15
Single vs. Multiple Temperature Mode	15
Changing Set Temperatures	16
Changing Food Group/Recipe Name	16
Changing Recipe Settings	17

Troubleshooting	18
------------------------	----

North America Limited Warranty	20
---------------------------------------	----

International Limited Warranty	23
---------------------------------------	----

Safety Instructions

Strictly adhere to the following safety precautions to reduce the risk of burns, electric shock, fire, injury, damage to oven or property near oven, or possible exposure to excessive microwave energy.

General Safety Information

- ✓ Read all instructions before using this appliance.
- ✓ Read and follow the specific "Precautions to Avoid Possible Exposure to Excessive Microwave Energy" found on page ii.
- ✓ This appliance must be grounded. Connect only to properly grounded outlet. See "Grounding Instructions" found on page ii.
- ✓ Install or locate this appliance only in accordance with the provided installation instructions.
- ✓ Some products such as whole eggs and sealed containers (e.g., closed glass jars) may explode and should not be heated in this oven.
- ✓ Use this appliance only for its intended uses as described in this manual.
- ✓ This appliance should be serviced only by qualified service personnel. Contact the nearest authorized service facility for examination, repair, or adjustment.
- ✓ Keep cord away from heated surfaces.
- ✓ Liquids, such as water, coffee, or tea are able to be overheated beyond the boiling point without appearing to be boiling. Visible bubbling or boiling when the container is removed from the microwave oven is not always present. **THIS COULD RESULT IN VERY HOT LIQUIDS SUDDENLY BOILING OVER WHEN THE CONTAINER IS DISTURBED OR A UTENSIL IS INSERTED INTO THE LIQUID.**
- x DO NOT allow children to use this appliance.
- x DO NOT use corrosive chemicals or vapors in this appliance - it is not designed for industrial or laboratory use.
- x DO NOT operate this appliance if it has a damaged cord or plug, is not working properly, or has been damaged or dropped. See Power Cord Replacement found on page ii.
- x DO NOT cover or block any openings on this appliance.
- x DO NOT store this appliance outdoors.
- x DO NOT use this product near water (e.g., near a kitchen sink, in a wet basement, near a swimming pool).
- x DO NOT immerse cord or plug in water.
- x DO NOT let cord hang over the edge of table or counter.
- x DO NOT use a water jet for cleaning. See the Maintenance section (pages 6-7) for proper cleaning procedures.

Reducing Fire Risk

- ✓ Remove wire twist-ties from paper or plastic bags used to facilitate cooking in the oven.
- ✓ If materials inside the oven ignite, keep the oven door closed, turn the oven off, and disconnect the power cord or shut off power at the fuse or circuit breaker panel.
- ✓ If smoke is observed, switch off or unplug the oven. Keep the door closed to stifle any flames.
- x DO NOT use the cook cavity for storage purposes.
- x DO NOT overcook food. Carefully attend to the oven if paper, plastic, or other combustible materials are placed inside the oven to facilitate cooking.
- x DO NOT leave paper products, cooking utensils, or food in the cavity when not in use.

SAVE THESE INSTRUCTIONS

Grounding Instructions

This appliance must be grounded. In the event of an electrical short circuit, grounding reduces the risk of electric shock by providing an escape wire for the electric current. This oven is equipped with a cord that has a grounding wire with a grounding plug, which must be plugged into an outlet that is properly installed and grounded. Consult a qualified electrician or serviceman if uncertain about the ability to follow grounding instructions or if doubt exists as to whether the appliance is properly grounded.

- x DO NOT use an extension cord. If the power cord is too short, have a qualified electrician or serviceman install an outlet near the appliance.



WARNING: Improper grounding can result in risk of electric shock.

Power Cord Replacement

If the power cord is damaged, it must be replaced by the manufacturer, its service agent, or a similarly qualified person.

Precautions to Avoid Possible Exposure to Excessive Microwave Energy

- Do not attempt to operate this oven with the door open since open-door operation can result in harmful exposure to microwave energy. It is important not to defeat or tamper with the safety interlocks.
- Do not place any object between the oven front face and the door or allow soil or cleaner residue to accumulate on sealing surfaces.
- Do not operate the oven if it is damaged. It is particularly important that the oven door close properly and that there is no damage to the: (1) Door (bent), (2) hinges and latches (broken or loosened), (3) door seals and sealing surfaces.
- The oven should not be adjusted or repaired by anyone except properly qualified service personnel.

RF Interference Considerations

The i5 oven generates radio frequency signals. This device has been tested and was determined to be in compliance with applicable portions of FCC part 18 requirements and to the protection requirements of Council Directive 89/336/EEC on the approximation of the laws of the Member States relating to electro-magnetic compatibility at the time of manufacture. However, some equipment with sensitivity to signals below these limits may experience interference.

If your equipment experiences interference:

- ✓ Increase the physical separation between this oven and the sensitive equipment.
- ✓ If the sensitive device can be grounded, do so following accepted grounding practices.
- ✓ If battery-powered microphones are being affected, ensure that the batteries are fully charged.
- ✓ Keep sensitive equipment on separate electrical circuits if possible.
- ✓ Route intercom wires, microphone wires, speaker cables, etc. away from the oven.

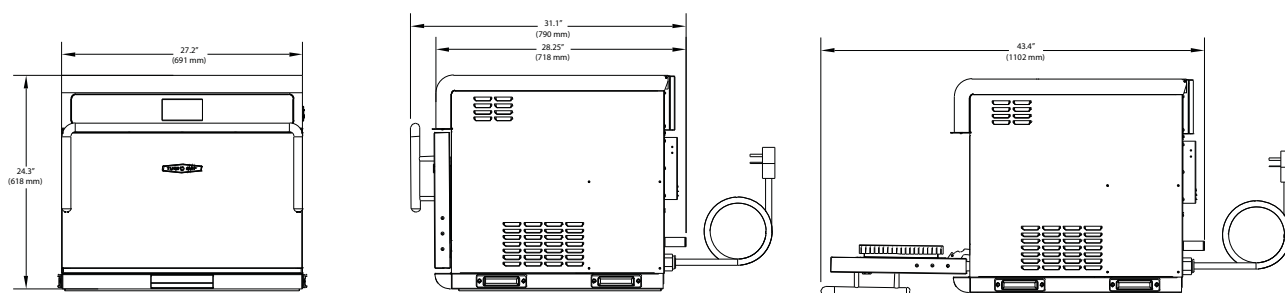

Figure 1: i5 Oven Dimensions

Theory of Operation

The i5 rapid cook oven combines precisely-controlled impinged air and microwave energy to create higher heat transfer rates than conventional ovens. Top-launched microwave and impinged air are stirred to further ensure even heat distribution, while impinged air enters the cavity from the top and bottom, generated by dual independently-controlled blower motors. The combination of this technology with the size of the cook cavity allows for higher throughput than other batch ovens.

This manual includes instructions for installing, cleaning, and operating the i5 oven. If you have questions that are not addressed in this manual, contact Customer Service (800.90TURBO, +1 214-379-6000) or your Authorized Distributor.

Certifications

cULus, UL EPH, TÜV, CE, FDA



Dimensions

Oven Dimensions

Height: 24.3" (618 mm)
 Width: 27.2" (691 mm)
 Depth (door closed): 28.25" (718 mm)
 Depth (door open): 43.4" (1102 mm)
 Weight: 275 lbs (125 kg)

Cook Cavity Dimensions

Height: 10" (254 mm)
 Width: 24" (610 mm)
 Depth: 16" (406 mm)
 Volume: 2.22 ft³ (63 liters)

Clearances

Top: 16" (406 mm)
 Sides: 2" (51 mm)

Oven Construction

Exterior

- Two-tone stainless steel front, top and sides
- 304 stainless steel removable grease pan
- Ergonomic door handle
- Rubber seal for surface mounting
- Side handles for lifting

Interior

- 304 stainless steel interior
- Fully-insulated cook chamber
- Removable rack with dual setting option
- Top and bottom jetplates

Electrical Specifications

TurboChef recommends a Type D circuit breaker for all installations outside the US.

Single Phase

i5 US model (i5-9500-1)

Voltage: 208/240 VAC*

Frequency: 60 Hz

Current: 48 amps

Max Input: 9500/11500 watts

Plug: NEMA 6-50P

i5 UK model (i5-9500-2-UK)

Voltage: 230 VAC

Frequency: 50 Hz

Current: 48 amps

Max Input: 10000 watts

Plug: IEC 309, 3-pin

i5 BK model (i5-9500-6-BK)

Voltage: 220 VAC

Frequency: 60 Hz

Current: 48 amps

Max Input: 10000 watts

Plug: IEC 309, 3-pin

i5 LA model (i5-9500-7-LA)

Voltage: 220 VAC

Frequency: 60 Hz

Current: 48 amps

Max Input: 10000 watts

Plug: NEMA 6-50P

i5 JK model (i5-9500-8-JK) - 50 Hz
(i5-9500-10-JK) - 60 Hz

Voltage: 200 VAC

Frequency: 50 or 60 Hz

Current: 46 amps

Max Input: 9000 watts

Plug: PSE-marked, 3-blade

* North America models include a voltage sensor which detects 208 or 240 VAC. The voltage sensor does not compensate for lack-of or over-voltage installations.

Multi Phase

i5 EW model (i5-9500-4-EW)

Voltage: 400 VAC

Frequency: 50 Hz

Current: 19 amps

Max Input: 10000 watts

Plug: IEC 309, 5-pin

i5 AU model (i5-9500-5-AU)

Voltage: 400 VAC

Frequency: 50 Hz

Current: 19 amps

Max Input: 10000 watts

Plug: Clipsal 5-pin

i5 KW model (i5-9500-12-KW)

Voltage: 400 VAC

Frequency: 60 Hz

Current: 19 amps

Max Input: 10000 watts

Plug: IEC 309, 5-pin

i5 ED model (i5-9500-3-ED)

Voltage: 230 VAC

Frequency: 50 Hz

Current: 28 amps

Max Input: 10000 watts

Plug: IEC 309, 4-pin

i5 SD model (i5-9500-13-SD)

Voltage: 230 VAC

Frequency: 60 Hz

Current: 28 amps

Max Input: 10000 watts

Plug: IEC 309, 4-pin

i5 JD model (i5-9500-9-JD) - 50 Hz
(i5-9500-11-JD) - 60 Hz

Voltage: 200 VAC

Frequency: 50 or 60 Hz

Current: 25 amps

Max Input: 10000 watts

Plug: PSE-marked, 4-blade

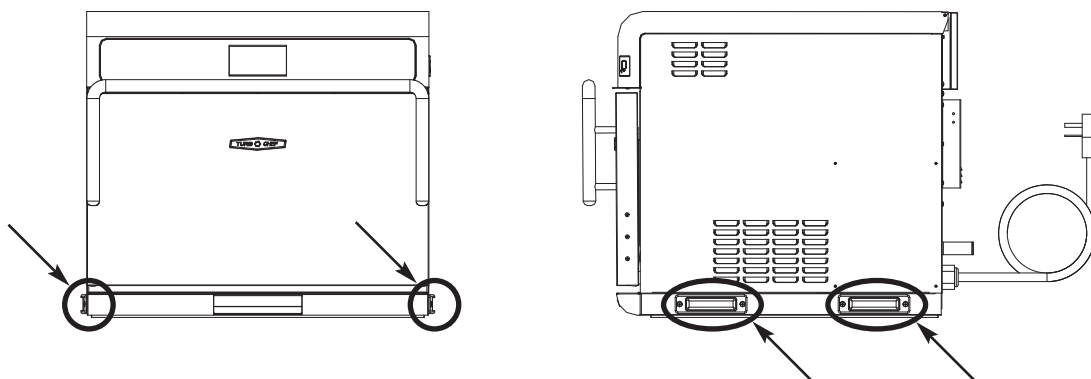

Figure 2: Hand Grip Locations

! Install or locate this appliance only in accordance with the instructions below.

Unpacking Instructions

1. Remove oven from packaging.
2. Before discarding packaging, check thoroughly for accessories, consumables, and additional literature.
3. Discard packaging.
4. Check cook cavity thoroughly for accessories, consumables, and additional literature.
5. Discard any packaging in cook cavity.

Lifting and Placing the Oven

! **WARNING:** Oven weighs approximately 275 lbs (125 kg). Never lift with fewer than two people.

! **WARNING:** Lift only from the sides of the oven, using the provided hand grips. Never lift the oven from the front and rear or by the door handle.

! **WARNING:** The oven must be properly placed on the table or countertop at all times. TurboChef will not recognize a fallen oven as a warrantable claim and is not liable for any injuries that may result.

! **WARNING:** This oven is not intended for built-in installation (i.e., installing the oven in any structure that surrounds the oven by five or more sides). Be sure to provide a minimum of 2" (51 mm) clearance for all sides and 16" (406 mm) clearance for the top.

1. Position one or more persons on the left and right sides of the oven.
2. Place hands into grips (see Figure 2) and lift.
3. Place the oven on a surface that is at least 30" (762 mm) deep and capable of supporting 280 lbs (127 kg). If installing onto an oven cart, make sure the wheels/casters are locked.
4. Install the oven rack or other provided cooking surface.
5. Plug in the oven.

! **NOTE:** The oven is primarily serviced through its top. **DO NOT** install shelving directly over the unit. The operator will be responsible for service charges incurred as a result of added time required to access the top of the oven.

Installation Near Open Heat Source

See Figure 4, page 5.

When placing a TurboChef oven near an open heat source, strictly adhere to the following:

- If the oven is being placed near a grill or stove, a divider must exist between the oven and the open heat source, with a minimum of 6" (152 mm) between the oven and the divider.
- If the oven is being placed near a fryer, a divider must exist between the oven and fryer, with a minimum of 12" (305 mm) between the oven and the divider.
- The height of the divider must be greater than or equal to the height of the oven (24.3" or 618 mm).
- Verify oven location has a minimum 16" (406 mm) clearance on top and minimum 2" (51 mm) of clearance on each side.

Optional Installation Items

See Figure 5, page 5.

TurboChef Oven Cart

- Part Number: NGC-1217-3
- Height: 32" (813 mm)
- Width: 27.8" (706 mm)
- Depth: 26.625" (676 mm)

Oven Restraint Kit

Part Number: TC3-0242

⚠ WARNING: The Oven Restraint Kit will not prevent the oven from falling off a countertop if the oven is pulled off or if the legs are allowed to slide off the edge. Installation instructions are included with the kit.

ChefComm Pro

ChefComm Pro is a PC program for developing and maintaining menus and recipes. To purchase ChefComm Pro and a card reader, contact customer service at 800.90TURBO or +1 214-379-6000.

Voltage Selection

For North America oven models, the oven will detect 208 or 240 incoming voltage.

The initial voltage selection is typically completed before the oven is used by the customer. However, if incoming voltage for the store is different than the preset voltage, the operator will be required to select either 208 or 240 after pressing the On/Off key to turn on the oven. The correct voltage will be enlarged on the screen, identifying which option to select (see Figure 3 below).

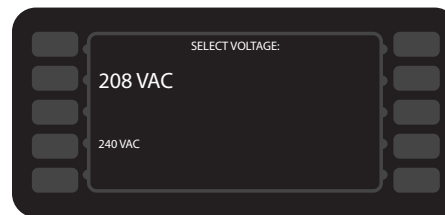

Figure 3: Selecting Voltage

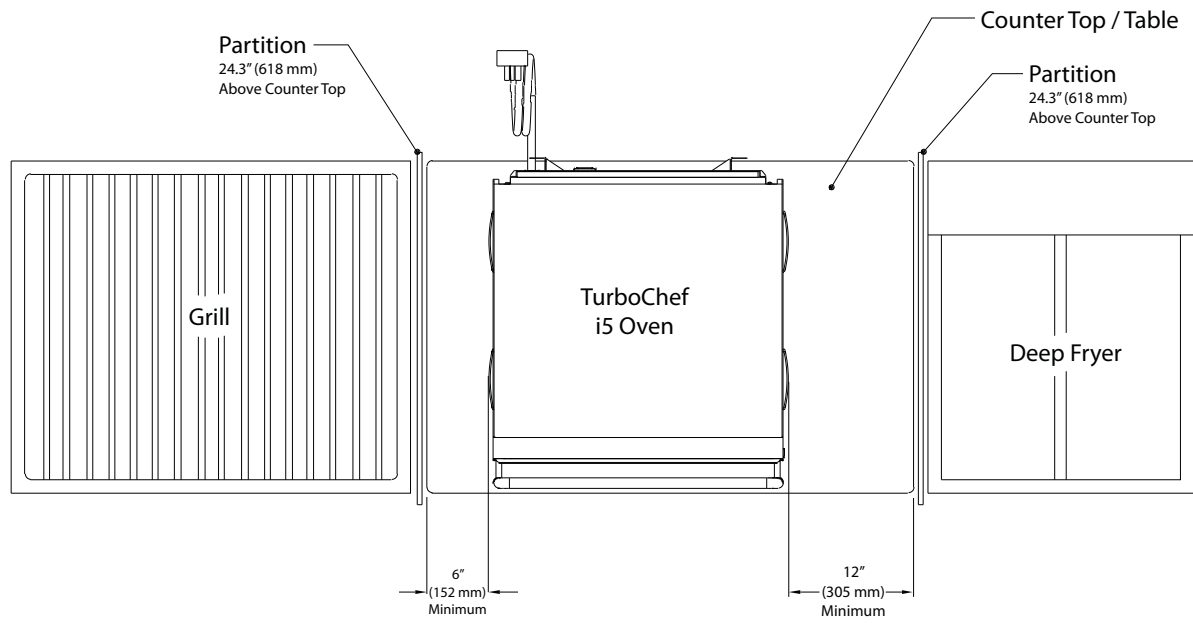

Figure 4: Installation Near Open Heat Source

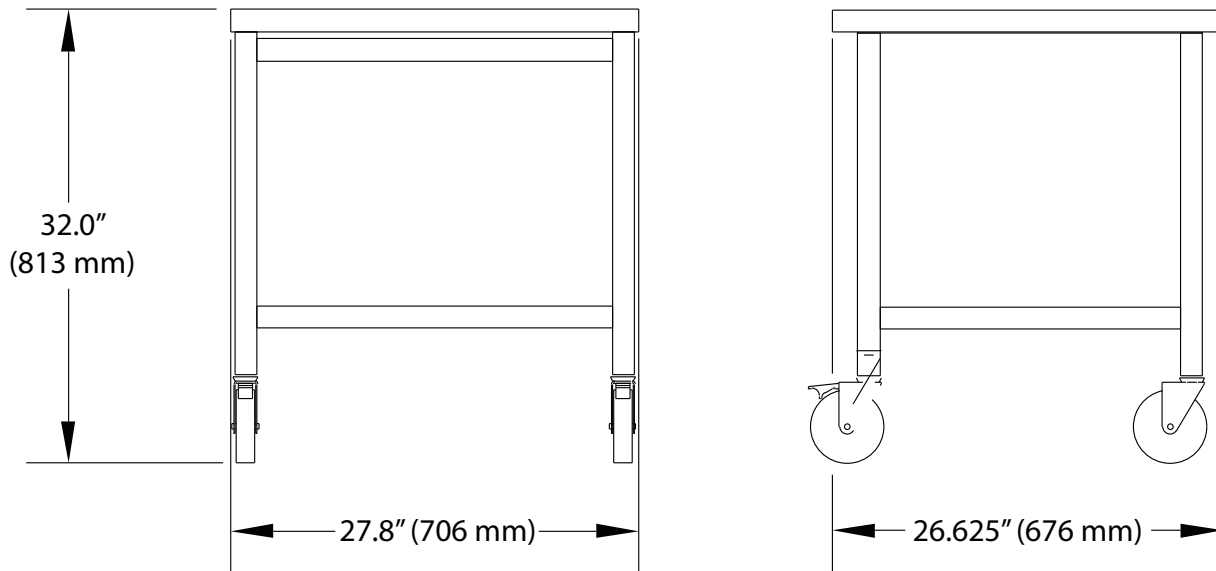

Figure 5: Oven Cart Dimensions

Daily Maintenance

The following steps will help maintain your i5 Oven. Use only TurboChef Oven Cleaner and Oven Guard. The use of any other cleaning products can damage critical oven components, resulting in a non-warranty service call.



Step 1

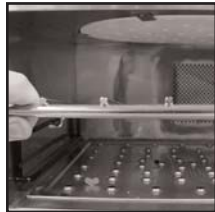

Step 2

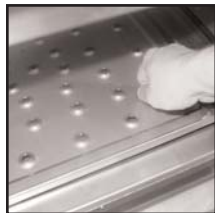

Step 3



Step 4



Step 5

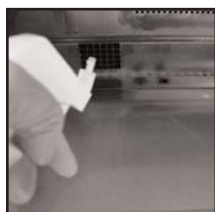

Step 6

Supplies and Equipment

- TurboChef Oven Cleaner (Part Number: 103180)
- TurboChef Oven Guard (Part Number: 103181)
- Nylon scrub pad, cleaning towel, disposable gloves, protective eyewear, dust mask (optional), *pair of tongs wrapped with towel (optional - see step 11)

Step 1: Prepare the Oven

⚠ WARNING: Oven operates at approximately 450°F (232°C) and may cause injury if not allowed to cool properly.

- Turn off the oven by pressing the On/Off key.
- Slightly open the oven door. Cooling takes approximately 40 minutes.
- DO NOT attempt to clean the oven until the oven displays “Oven Off”.

Step 2: Remove and Clean the Wire Rack

⚠ WARNING: Be sure the oven interior is cool before you remove the wire rack.

- Wash, rinse, and sanitize the wire rack.

Step 3: Remove and Clean the Lower Jetplate

- Unscrew the two thumb screws on the lower jetplate.
- Lift the lower jetplate by gripping the thumb screws.
- Remove the lower jetplate.
- Wash, rinse, and sanitize the lower jetplate.

Step 4: Remove and Clean the Lower Air Diverter

- Remove the lower air diverter.
- Wash, rinse, and sanitize the lower air diverter.

⚠ WARNING: DO NOT discard the lower air diverter. The oven will not work without the lower air diverter installed.

Step 5: Wipe the Oven Interior

- Wipe any large particles from the oven interior with a damp towel.

Step 6: Clean the Oven Interior

- Spray oven cleaner onto the top, bottom, and sides of the oven interior.

⚠ CAUTION: DO NOT spray oven cleaner into the perforation on the back oven wall. Doing so can damage critical oven components, resulting in a non-warranty service call.

- Allow Oven Cleaner to penetrate stains for five minutes.
- Clean the oven interior with a nylon scrub pad.

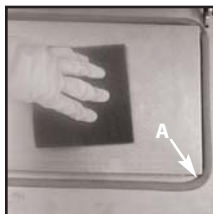

Step 7

Step 7: Clean and Dry the Oven Door

- ⚠ CAUTION: DO NOT spray oven cleaner directly onto the oven door gasket (A) or saturate it with water.
- ⚠ CAUTION: DO NOT scrub or attempt to clean the oven door gasket (A). Doing so may cause the oven door to misalign, resulting in a non-warranty service call.
 - Clean oven door with oven cleaner and a nylon scrub pad.
 - Wipe the oven door with a damp towel.



Step 8

Step 8: Rinse the Oven Interior

- ⚠ CAUTION: DO NOT use a hose or water jet for cleaning. Doing so can damage critical oven components, resulting in a non-warranty service call.
 - Rinse the oven interior with clean water.
 - Dry the oven interior with a clean towel.



Step 9

Step 9: Apply TurboChef Oven Guard

- Spray Oven Guard onto a clean towel.
- Wipe the oven's interior walls and the inside of the oven door.
- ⚠ CAUTION: DO NOT apply Oven Guard to the oven door gasket. Doing so may damage the gasket, resulting in a non-warranty service call.



Step 10

Step 10: Reinstall Components

- Reinstall the lower air diverter.
- Reinstall the lower jetplate. Screw in the two thumb screws to lock the lower jetplate in place.
- Reinstall the wire rack.
- Close the oven door.



Step 11

Step 11: Clean the Drain Pan

- Remove the drain pan entirely from the bottom of the oven.
- Wipe down* the inside of the area the drain pan fits within.
- Empty, clean, and reinstall the drain pan.
- ⚠ CAUTION: Ensure the drain pan's outer edge is flush with the door panel (i.e. not sticking out). Failure to do so will damage the oven door, resulting in a non-warranty service call.



Step 12

Step 12: Clean the Oven Exterior

- Wipe the oven exterior with a clean, damp towel.
- ⚠ CAUTION: DO NOT spray chemicals into any openings, such as the louvers on the side panels or the rear vent catalyst housing. Doing so can damage critical oven components, resulting in a non-warranty service call.

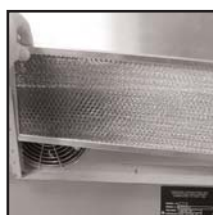

Step 13

Step 13: Clean the Air Filter (once a week)

- Remove the air filter from the back panel.
- Wash in dishwasher or rinse with hot water.
- DO NOT use a water jet. Doing so will shorten the life of the filter.
- Reinstall the air filter.
- ⚠ CAUTION: DO NOT operate the oven without the air filter in place.



Figure 6: Oven Controls

Oven Controls

1. Info Key

When the oven is off or cooling down, press to access the INFO MODE (see page 12).

2. On/Off Key

When the oven is cooling down or off, press to turn on the oven.

When the oven is on or warming up, press to turn off the oven.

When the oven is in the INFO MODE (see page 12), press to return the oven to the “Cooling Down/Oven Off” screen.

3. Display

The display shows information relevant to the current oven operation and/or user options.

4. Soft Keys

There are ten soft keys - five to the left (L1 thru L5, where L1 = top) and right (R1 thru R5, where R1 = top) of the display. Press a soft key to select an option adjacent to that key on the display.

5. Back/Stop Key

When the oven is cooking, press the Back/Stop key to immediately terminate a cook cycle.

When the oven is in the IDLE MODE (see page 10, mode 5) or the INFO MODE (see page 12), press to return to the previous screen.

6. Up and Down Keys

When the oven is ready to cook (i.e., warmed up and waiting for a cook command), press the Up or Down arrow to view additional food groups (if applicable).

When the oven is in the INFO MODE (see page 12), press to navigate between and within menus.

7. Enter Key

Press the Enter key to confirm a selection (where applicable).

8. Numeric Keypad

Use the numeric keypad to program the oven or modify cook settings. The numeric keypad also contains a Back/Stop key and an Enter key, which are functionally identical to Items 5 and 7 (above).

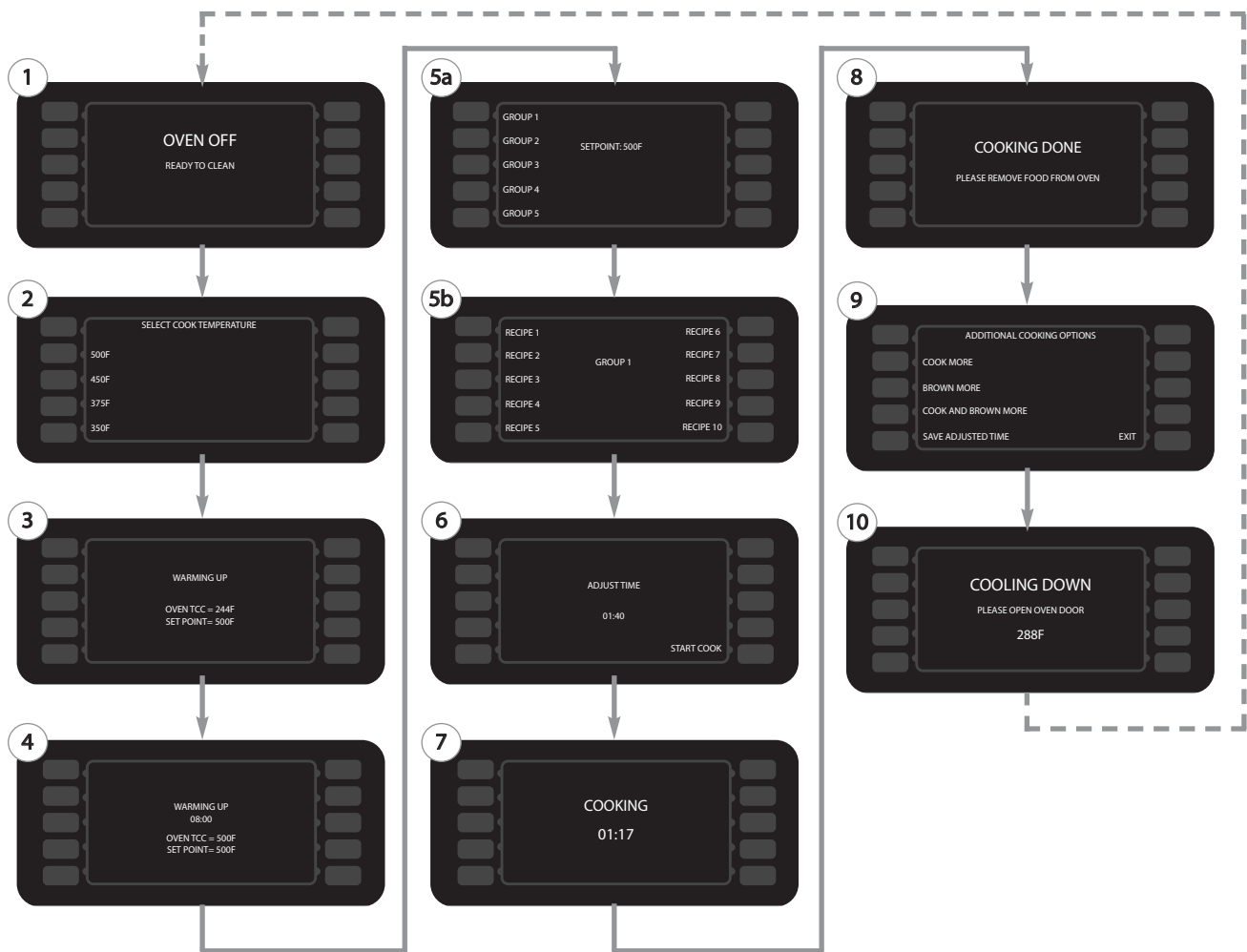

Figure 7: Standard Operation Modes

Cooking

This section explains how to cook a food product by describing the “standard operation” modes through which the oven progresses.

The oven is preprogrammed with recipe settings at the time of manufacture and is ready to operate out of the box. If these settings are erased, new menu settings must be either loaded via smart card/USB drive (page 14) or programmed manually (pages 15-17). The oven will not cook unless settings are present.

Note that modes are not always sequential, as shown in Figure 7, above. Typically, modes 5-9 will be repeated before cooling the oven (mode 10).

- MODE 1: Oven Off
- MODE 2: Temperature Select (if applicable)
- MODE 3: Warming Up
- MODE 4: Soak
- MODE 5: Ready to Cook (or “Idle”)
- MODE 6: Adjust Time (if enabled)
- MODE 7: Cooking
- MODE 8: Remove Food from Oven
- MODE 9: Cook More (if enabled)
- MODE 10: Cooling Down

Mode 1: Oven Off

Mode during which all cooking components are off and the oven temperature has receded below 150°F (66°C), but the display and keypad remain on.

Happens When...

- The oven completes MODE 10.

Goes To...

- MODE 2 when On/Off key is pressed.
- INFO MODE (page 12) when Info key is pressed.

Mode 2: Temperature Select

NOTE: If cooking with only one temperature, this screen will be bypassed.

The i5 Oven can store up to four different cook temperature settings. Each temperature setting has 5 food groups assigned to it, each consisting of 10 food recipes (50 recipes per temperature setting).

NOTE: Earlier i5 models store only two temperatures, each containing 100 food recipes.

The operator will be able to cook only recipes associated with the selected temperature setting. See “Edit Mode,” page 15 for more information on using and changing multiple temperatures.

To select a temperature (if applicable), press the adjacent soft key.

Happens When...

- The On/Off key is pressed from MODE 1.
- The Back key is pressed from MODE 3.

Goes To...

- MODE 3 when a temperature is selected.
- MODE 1 or 10 if the On/Off key is pressed.

Mode 3: Warming Up

Mode during which the oven warms to the pre-set cook temperature.

Happens When...

- A temperature is selected from MODE 2 (if multiple temperatures are present).
- On/Off key is pressed from MODE 1 or 10 (if single temperature is present).

Goes To...

- MODE 4 when the oven temperature reaches the selected set temperature - if the oven temperature needed to recover more than 125°F (70°C) at the time warmup initiated.

- MODE 5 when the oven temperature reaches the selected set temperature - if the oven temperature needed to recover less than 126°F (70°C) at the time warmup initiated.
- MODE 10 if the On/Off key is pressed.

Mode 4: Soak

SOAK MODE provides an additional 8 minutes of warmup time for the cook cavity surfaces to warm.

Happens When...

- MODE 3 completes - if the oven temperature needed to recover more than 125°F (70°C) at the time warmup initiated.

Goes To...

- MODE 5 when counter reads 00:00.
- MODE 10 if the On/Off key is pressed.

Mode 5: Ready to Cook (or “Idle”)

Mode during which a food group and item can be selected for cooking.



WARNING: Inside of oven and oven door are hot! Use extreme caution.

1. Place the food into the oven.
2. Select a food group by pressing its adjacent soft key, or press the Up key or Down key for additional food groups, if available.
3. Select an item to cook by pressing its adjacent soft key.

Happens When...

- MODE 3 or 4 completes.

Goes To...

- MODE 6 if food item is selected and “Adjust Time” is enabled (see page 13).
- MODE 7 if food item is selected and “Adjust Time” is disabled.
- MODE 10 if the On/Off key is pressed.

Mode 6: Adjust Time

After a food item has been selected to cook, it may be necessary to change the cook time. Do so using the number keys, and then press the Enter key to confirm the change.

The ADJUST TIME MODE can be turned on or off from the “Options” screen (see page 13). It is turned off by default.

Happens When...

- ADJUST TIME MODE is enabled and a food item is selected from MODE 5.

Goes To...

- MODE 7 when “Start Cook” is selected.
- MODE 10 if the On/Off key is pressed.

Mode 7: Cooking

Mode during which the oven cooks a food item.

NOTE: To immediately terminate a cook cycle, press the Back/Stop key.

NOTE: If the oven door is opened during a cook cycle, the cycle will pause until the door is closed and “Resume” is selected.

Happens When...

- A food item is selected from MODE 5 if MODE 6 is disabled.
- “Start Cook” is selected from MODE 6.

Goes To...

- MODE 8 when the cook cycle completes.

Mode 8: Remove Food from Oven

Mode during which the oven beeps until the oven door is opened. During this mode, the oven temperature remains constant.



WARNING: Dish and inside of oven/oven door are hot! Use extreme caution.

Happens When...

- A cook cycle completes.

Goes To...

- MODE 9 if “Cook More” is enabled (page 13).
- MODE 5 if “Cook More” is disabled.
- MODE 10 if the On/Off key is pressed.

Mode 9: Cook More

At the completion of a cook cycle, the user has the option to cook an item longer per the following:

- Select “cook more” if the inside of the dish is not done.
- Select “brown more” if the outside of the dish is not done.
- Select “cook and brown more” if both the inside and outside of the dish are not done.
- Select “save time” to save any change to the cook time made during MODE 6. Note that this option is not available if MODE 6 is disabled.
- Select “exit” to return to the food group selection screen.

Cook More mode can be enabled/disabled from the Options menu (see page 13). It is disabled by default.

Happens When...

- A cook cycle completes.

Goes To...

- MODE 7 if one of the “Cook More” options is selected.
- MODE 5 if “Save Time” is selected, “Exit” is selected, or if nothing is selected after 10 seconds.
- MODE 10 if the On/Off key is pressed.

Mode 10: Cooling Down

Mode during which the oven blows cool air into the cook cavity to return it to room temperature.

Happens When...

- The On/Off key is pressed from MODES 2-6, 8-9.

Goes To...

- MODE 1 when the oven temperature recedes below 150°F (66°C).
- INFO MODE (page 12) when the Info key is pressed.

Overview of the Info Mode

The INFO MODE SERVES four main purposes:

1. To display oven information.
2. To provide access to TEST MODE and additional diagnostic tools for service technicians.
3. To turn oven options and features on/off.
4. To update oven settings.

To access the INFO MODE, simply press the “Info” key when the oven is either off or cooling down.

The INFO MODE consists of two screens. To toggle between screens, press the Up key or Down key.

From screen 1 of the INFO MODE (Figure 8):

- View the oven serial number
- View the oven software version
- View the menu part number and revision
- View the last temperature selected to cook
- View the electrical compartment temperature
- View the cook counts, cook time, magnetron time, and cumulative oven on time
- View the operating voltage (North America models only)
- Access the fault log
- Access service phone numbers
- Reset the oven

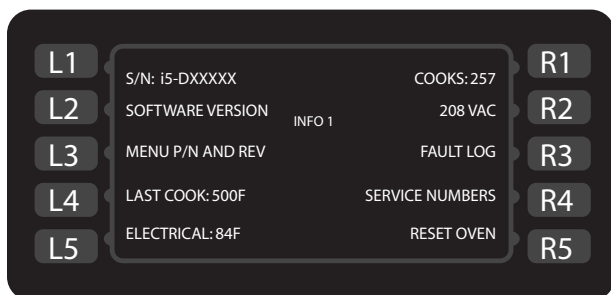

Figure 8: Info Mode Screen 1

From screen 2 of the INFO MODE (Figure 9):

- Access TEST MODE
- Access the “Options” screen
- Set the language (not available on all oven models)
- Set the date/time
- Erase oven settings and stored data (manufacturing/service use only)
- Access the “Load Menu” screen

Viewing Cook Counts/Time Logs

From screen 1 of INFO MODE, press the R1 soft key:

- Once to display the cumulative cook count.
- Twice to display total cook time.
- Three times to display total magnetron time.
- Four times to display total “oven on” time.

Viewing the Fault Log

Figures 10-11.

From screen 1 of the INFO MODE, press the R3 soft key to view the fault log (Figure 10). To view a detailed log of each fault occurrence (Figure 11), press the soft key adjacent to the fault code.

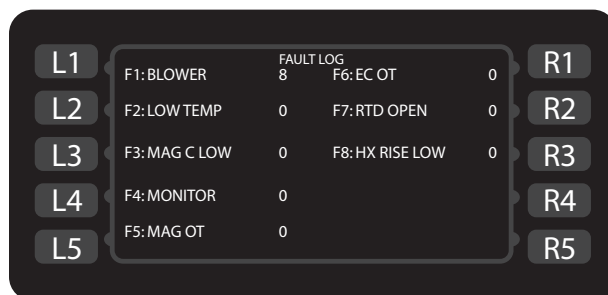

Figure 10: Fault Log

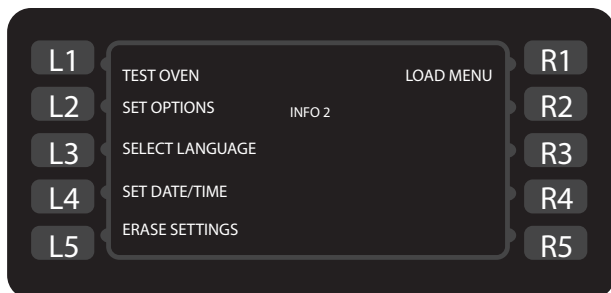

Figure 9: Info Mode Screen 2

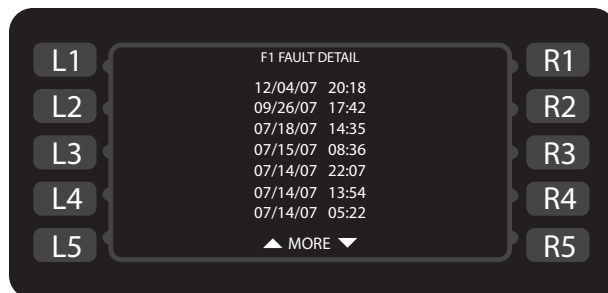

Figure 11: Fault Detail

Viewing the Service Numbers

From screen 1 of the INFO MODE, press the R4 soft key to view the phone numbers for TurboChef Technical Support.

Resetting the Oven

Resetting the oven is one way to potentially clear an error message, should one occur. From screen 1 of the INFO MODE, press the R5 soft key.

Setting the Date/Time

Having an accurate date and time is important for logging oven counts and diagnostics, as well as fault conditions should any occur. The oven time and date are set at the time of manufacture; however, the operator may at some point be required to make an adjustment.

From screen 2 of the INFO MODE, press the L4 soft key to access the “Set Date/Time” screen.

To set the date and time (Figure 12, below):

1. Use the L3 and R3 soft keys (middle left and middle right) to navigate between fields.
2. Use the numeric keypad to enter the month, day, and year, followed by hour and minute.

NOTE: The clock is a 24-hour clock (e.g., 20:30 = 8:30 PM).

3. Select “Save” to save your changes or “Cancel” to cancel and exit the screen.

NOTE: The oven will not retain the time if it is left unplugged for two or more weeks.

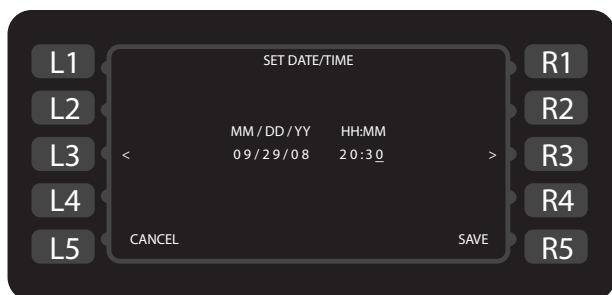

Figure 12: Set Date/Time

Turning Oven Options On/Off

Figure 13.

From screen 2 of the INFO MODE, press the L2 soft key to access the “Options” screen. When prompted, enter the password 9 4 2 8 and press the Enter key.

From the “Options” screen, the following oven options can be turned on or off:

- “Adjust Time” screen (page 10 for more details)
- “Cook More” screen (page 11 for more details)
- Edit Mode (page 15 for more details)
- “Load Menu” screen (page 14 for more details)
- Demo Mode (TurboChef use only)
- DHCP (TurboChef use only)

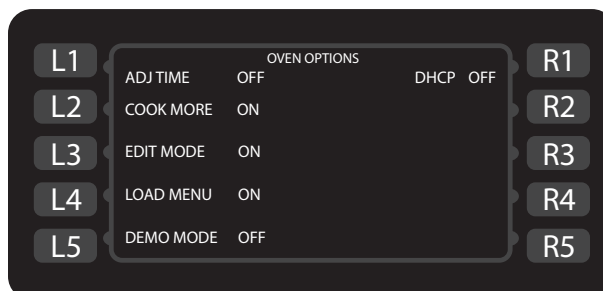

Figure 13: Options Screen

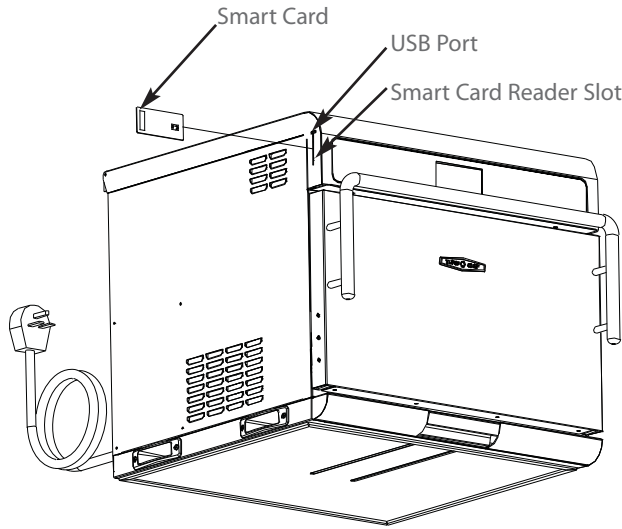

Figure 14: Inserting Smart Card/USB Device

Loading a Menu

From screen 2 of the Info mode, press the R1 soft key to access the “Load Menu” screen (Figure 15).

NOTE: This feature can be turned on or off via the “Options” screen (page 13).

To load a menu to the oven,

1. Insert the source (smart card or USB - see Figure 14).
2. Press the L1 soft key to load from a smart card, or the L4 soft key to load from USB* (Figure 15).
3. Verify the oven beeps and reads “FINISHED” (Figure 16).

* NOTE: To successfully load a menu from USB:

- The menu file must be a binary (.BIN) file
- The menu file name must be MENU**DATA**.BIN
- The menu file must exist in a top-level folder, i.e., the folder cannot be a sub-folder of any other folder on the USB device.
- The folder name must be TC_MENU**S**

To save a copy of a menu from the oven,

1. Insert the source (smart card or USB - see Figure 14).
2. Press the L2 soft key to save to a smart card or the L5 soft key to save to USB** (Figure 15).
3. Verify the oven beeps and reads “FINISHED” (Figure 16).

** NOTE: To successfully save a menu to USB:

- The USB device must contain a top-level folder titled TC_MENU**S**
- This folder cannot be a sub-folder of any other folder on the USB device. Rather, it must be top-level.

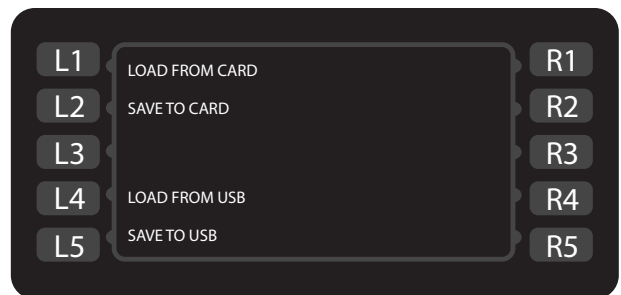

Figure 15: Load Menu Screen

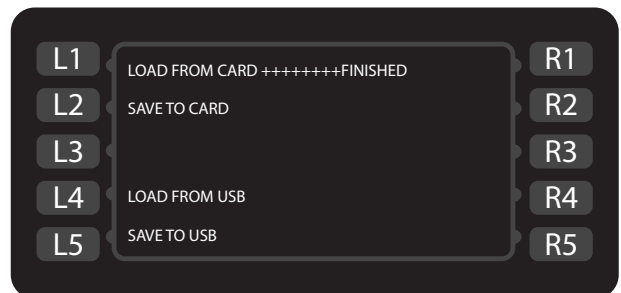

Figure 16: Loading...Finished

Overview of the Edit Mode

The EDIT MODE serves three main purposes:

1. To edit set temperatures.
2. To edit names of food groups and recipes.
3. To edit recipe settings.

To access the EDIT MODE,

1. Enable it from the “Options” screen (page 13).
2. Press the On/Off key to return the oven to the “Cooling Down” or “Off” screen.
3. Press the On/Off key again to enter EDIT MODE.

Single vs. Multiple Temperature Mode

The i5 Oven is capable of utilizing four unique set temperatures. By default, the oven operates in “Single Temperature” mode, in which all four temperatures are the same. By contrast, if more than one temperature is specified in the EDIT MODE, the oven will operate in “Multiple Temperature” mode.

The i5 Oven is capable of storing 200 recipes. If more than one temperature is desired, at least 50 recipe spots must be allocated to each unique temperature setting. Think of each temperature as a “block” of 5 food groups, or 50 recipes. The table below outlines differences between the two modes in more detail.

NOTE: Earlier i5 models store only two temperatures, each containing 100 food recipes.

	Single Temperature Mode	Multiple Temperature Mode
Edit Mode:	<ul style="list-style-type: none"> - Four temperatures available to edit (Figure 16, page 16). - Adjacent soft key to access recipes associated with temperatures (Figure 16, page 16). - When in “group select” (Figure 17, page 16), all 200 recipes will be available to edit (because all temperature settings are identical). - Temperature displayed adjacent to each “block” of five food groups (Figure 17, page 16). 	<ul style="list-style-type: none"> - Same as single temperature mode. - Same as single temperature mode. - When in “group select” (Figure 17, page 16), only recipes associated with the selected temperature will be available to edit. (NOTE: if additional temperature settings are identical to the one that was selected, the associated recipes for those temperature settings will also be available to edit.) - Same as single temperature mode.
Cook Mode:	<ul style="list-style-type: none"> - No temperature selection screen. The oven automatically warms up when the On/Off key is pressed (Figure 7.3, page 9). 	<ul style="list-style-type: none"> - When the oven is turned on, select a temperature before warming up (Figure 7.2, page 9).
Number of Recipes Available to Cook:	<ul style="list-style-type: none"> - 200 (all) 	<ul style="list-style-type: none"> - If 2 unique temperatures: 100/100 or 150/50 - If 3 unique temperatures: 100/50/50 - If 4 unique temperatures: 50/50/50/50

Table 1: Single Temperature Versus Multiple Temperature Mode

Changing Set Temperatures

If a menu was loaded via smart card or USB (page 14), the temperatures are already set - they need not be changed. The operator should never change the set temperatures during normal operation.

Changing the set temperatures is not advised to compensate for over-cooking or under-cooking situations. Rather, consult your authorized distributor or TurboChef Customer Service if recipe settings are not cooking as desired.

To change a set temperature,

1. Place the oven in EDIT MODE (see page 15).
2. Select the temperature to change by pressing the adjacent soft key (Figure 16).
3. Using the number keys, enter the new set temperature.
4. Press the Enter key to confirm the change, or the Back/Stop key to cancel.



Figure 16: Temperature Edit Screen

Changing Food Group/Recipe Name

To change a food group or recipe name,

1. Place the oven in EDIT MODE (see page 15).
2. Select a “block” of food groups by pressing the corresponding right-side soft key (Figure 16).

NOTE: Earlier i5 models store only two temperatures, each containing 2 food group “blocks.”

3. Select the group that contains the recipe(s) you want to edit (Figure 17).
4. Select a recipe to edit (Figure 18).
5. From the “Recipe Edit” screen (Figure 19), edit the food group name:
 - Use the numeric keypad to change a character.
 - Press the R1 soft key to advance to the next character.
 - Press the L1 soft key to return to the previous character.
 - Press the R3 soft key to save changes.
6. Edit the recipe name:
 - Press the Down key to move to the “Recipe Name” field.
 - Use the instructions provided in step 5 to edit the recipe name.



Figure 18: Select Recipe to Edit

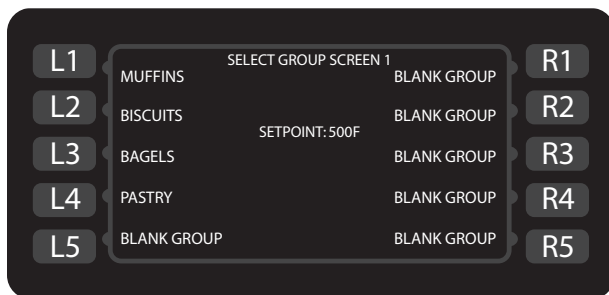

Figure 17: Select Food Group

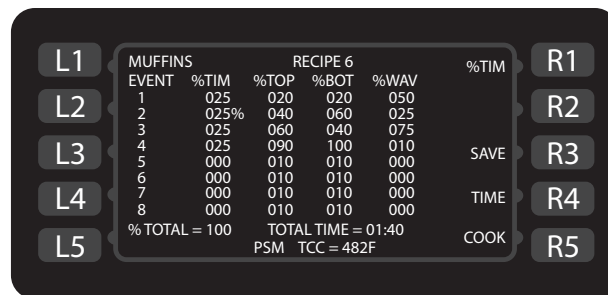

Figure 19: Recipe Edit Screen

Changing Recipe Settings

Recipe settings consist of the following:

- Up to eight “events” or stages of the cook cycle.
- Cook time.

To change recipe settings,

1. Place the oven in EDIT MODE (see page 15).
2. Access the “Food Group” screen (Figures 16-17).
3. Select a recipe to edit (Figure 18).
4. Use the Down key to move the cursor to the desired “Event Setting” field (Figure 19).

NOTE: To help make navigation easier, the currently-selected field will be displayed in the top-right corner of the display. In Figure 19, the cursor is in the %TIM column.

5. Use the number keys to adjust event settings:
 - % Time (0-100% in 1% increments). The sum of the percentages across eight events must equal 100.
 - % Top Blower (10-100% in 10% incr.)
 - % Bottom Blower (10-100% in 10% incr.)
 - % Microwave (0-100% in 10% incr.)

6. Use the Down key to move the cursor to the “Total Time” field.

NOTE: To help make navigation easier, the R4 “Time” soft key jumps the cursor to the total time field.

7. Use the number keys to adjust the cook time.
8. Press the R3 soft key to save changes.

NOTE: For the save to take effect, the cursor must be advanced past the field that was last edited.

9. If desired, press the R5 soft key to test-cook the new settings. In doing so, the oven may require additional warmup time.
10. When all editing is complete, return to the “Options” screen and turn off the EDIT MODE (see page 13). This will allow access into the regular cook mode.

Troubleshooting

The following is a list of fault codes and error messages, along with the possible problem(s) that the oven may be experiencing. Please attempt the recommended action before calling Customer Service (800.90TURBO, +1 214-379-6000) or your Authorized Distributor.

NOTE: Any fault codes listed in **bold** will terminate a cook cycle upon discovery. F6 will not terminate a cook cycle; however, it will alert the user of a possible air circulation problem.

 **WARNING:** Dish, oven door, and oven cavity are hot! Use extreme caution when troubleshooting the issues below.

Issue	Possible Cause(s)	Resolution
No power to oven.	<ul style="list-style-type: none"> - Oven is not plugged in. - Main circuit breaker is tripped. 	<ul style="list-style-type: none"> - Plug oven in. - Verify wall circuit breaker is on. Reset breaker and then power oven back on.
Oven is not warming up properly.	<ul style="list-style-type: none"> - Oven is in OFF state. - Door is not closed. - Oven has been switched off at the main circuit breaker. - Hi-limit tripped 	<ul style="list-style-type: none"> - Press the “On/Off” soft key. - Close the cook cavity door. - Place the oven in the OFF state and unplug the oven – leave for two minutes. Re-plug in the oven, switch on the isolator/main power supply, and press the “On/Off” soft key. - Reset the high-limit located in the bottom-left corner of the oven rear wall.
Display reads “Oven Door Open” and alarm sounds.	<ul style="list-style-type: none"> - Food obstruction preventing door from closing. - Oven door is open. - Door switches are out of alignment. 	<ul style="list-style-type: none"> - Open door and remove obstruction. - Open and close the door several times. - Call Customer Service.*
Oven is not cooking properly.	<ul style="list-style-type: none"> - Oven is not clean. (Large deposits of grease, carbon, or food debris dilute the microwave.) - Incorrect Group and/or Item name was selected for the product. - Product was not cooked from correct starting state (for example, chilled or frozen). - Rack incorrectly positioned. - Lower air diverter is missing. 	<ul style="list-style-type: none"> - Clean the oven following the cleaning instructions on pages 6-7. - Check to make sure correct food group and/or item was selected for the product being cooked. - Ensure product was in the correct state before being placed in the oven. - Verify the rack is in the correct position. - Verify the air diverter is present. Make sure it was reinstalled when cleaning (see pages 6-7).

Issue	Possible Cause(s)	Resolution
F1: Blower Running Status Bad	<ul style="list-style-type: none"> - Oven power interrupted. 	<ul style="list-style-type: none"> - Verify wall circuit breaker is on. Reset breaker and then power the oven on. - Place the oven in the OFF state and unplug the oven – leave for two minutes. Re-plug in the oven, switch on the isolator/main power supply, and press the “On/Off” soft key.
F2: Cook Temperature Low	<ul style="list-style-type: none"> - Oven power interrupted. - Air nozzles on the top/bottom of the cook cavity are clogged. - Oven door is out of alignment. - Defective heater. - Blower motor not running. - Oven not fully warmed-up. 	<ul style="list-style-type: none"> - Verify wall circuit breaker is on. Reset breaker and then power oven back on. - Open oven door and verify the air nozzles on the top/bottom of the cook cavity are clean and not clogged. - Open and close the door several times and verify oven door is closed. - Reset high-limit located in the bottom left corner of the oven rear wall. - Call Customer Service.* - Repeat warm-up and allow oven to idle for five minutes.
F3: Magnetron Current Low	<ul style="list-style-type: none"> - Microwave circuit defective. 	<ul style="list-style-type: none"> - Call Customer Service.*
F4: Door Monitor Defective	<ul style="list-style-type: none"> - Oven door switches are out of order. 	<ul style="list-style-type: none"> - Call Customer Service.*
F5: Magnetron Over Temperature	<ul style="list-style-type: none"> - Blockage of cool air into the oven. - Rear cooling fan exhaust guard(s) clogged. 	<ul style="list-style-type: none"> - Check for and remove anything that may be obstructing the flow of cool air into the oven. - Check rear fans to see if they are free of debris. Clean as required.
F6 EC Temp	<ul style="list-style-type: none"> - Blockage of cool air into the oven. - Rear cooling fan exhaust guard(s) clogged. 	<ul style="list-style-type: none"> - Check for and remove anything that may be obstructing the flow of cool air into the oven. - Check rear fans to see if they are free of debris. Clean as required.

North America Limited Warranty

TurboChef “i5” Rapid Cook Oven – North America

The TurboChef rapid cook oven Limited Warranty outlined below is activated upon shipment of your oven. Should you require additional assistance after reviewing the warranty outlined below, please call TurboChef Customer Service at 800.90TURBO.

Limited Warranty

TurboChef Technologies, Inc. (“TurboChef”) warrants to you, the purchaser, that under normal use the TurboChef rapid cook oven you have purchased (the “Equipment”) will be free from defects in material and workmanship during the Warranty Period, subject to the terms and conditions set forth herein. The “Warranty Period” is twelve (12) months from the date the Equipment is shipped from TurboChef’s U.S. factory or distribution center. This warranty is conditioned upon you promptly notifying TurboChef of any claims, as provided in the paragraph entitled “Warranty Claims” below, and providing TurboChef with all data and information requested by TurboChef or its service agents in connection with such claims as well as all necessary access to your premises and the Equipment. This warranty is made only to the initial purchaser of the Equipment from TurboChef or its authorized dealer; it is not assignable to subsequent purchasers unless TurboChef consents to such assignment in writing.

Disclaimer of Warranties

Except as provided in the Limited Warranty above, the Equipment is provided “as-is”. TurboChef disclaims all other warranties, express, statutory or implied, including without limitation, the implied warranties of title, non-infringement, merchantability and fitness for a particular purpose. TurboChef does not warrant that the Equipment will meet your specifications or needs. You acknowledge that you are solely responsible for the selection of the Equipment and determining the suitability of the Equipment for your needs.

Warranty Exclusions

Improper Installation, Operation or Maintenance: Equipment that is not installed, operated and maintained in accordance with TurboChef’s rapid cook oven owner’s manual (as may be updated by TurboChef from time to time, the “Manual”), a copy of which is provided to you with the Equipment or otherwise will be furnished to you upon request, is excluded from this warranty. This warranty does not apply to damage or failure which results, in TurboChef’s or its service agent’s sole opinion, from failure to provide a suitable installation and operating environment (including power and HVAC) and facilities as prescribed by the Manual, misuse, abuse, accident, neglect, power failure or power surges (over or under voltage), or to damage or failure from flood, fire, lightning or other natural or man-made disasters, or other Acts of God, or to Equipment that has missing or altered serial numbers.

Modifications and Repair: Equipment that has been modified or altered by persons other than TurboChef or its service agents, or Equipment that has had non-approved devices or connection items attached thereto, is excluded from coverage under this warranty. Repair of the Equipment by anyone other than TurboChef or its authorized service agents will void all warranties on the Equipment.

Accessories: Accessories and parts (collectively “Accessories”) that are consumed in the normal course of Equipment operation or maintenance are excluded from this warranty. Failure of or damage to Equipment or components from the use of non-approved cleaning chemicals, devices or processes is also excluded from this warranty. Accessories may include, but are not limited to, ceramic cooking platters, paddles and approved cleaning chemicals and devices.

Outstanding Invoices: If the full invoiced amount for Equipment purchased has not been paid within forty-five (45) days from the invoice date, then TurboChef will have no obligation to honor this or any other warranty on the Equipment until payment is received in full, including any accrued interest or other charges, has been satisfied, at which time warranty coverage will be reinstated, but the Warranty Period will not be extended.

Warranty Service, Exclusive Remedy

TurboChef will be solely responsible for determining whether or not the Equipment or any component thereof is defective. Defective components covered by this warranty will be repaired or replaced at TurboChef’s option without charge to you and such repaired or replacement components will be covered by this warranty for the balance of the Warranty Period. Parts used in the repair of defective components and replacement components may be new, recovered or rebuilt. At its sole option, TurboChef may decide to replace defective Equipment covered by this warranty with new, recovered or rebuilt Equipment of equal or greater capability, and such Equipment will be covered by this Limited Warranty for the balance of the Warranty Period. Defective Equipment and components will become the property of TurboChef. This paragraph states TurboChef’s sole and exclusive obligation and liability and your sole and exclusive remedy under this warranty. TurboChef shall not be responsible for a failure to provide warranty services due to causes beyond TurboChef’s or its service agents’ control.

Warranty Claims

Claims under this warranty must be reported to TurboChef during our normal working hours at the following number: 800.90TURBO, or such other reporting service as TurboChef may designate. Upon receipt of the claim and related information and preliminary verification that the claim is valid, TurboChef will promptly notify an authorized service agent to contact you and arrange for an on-site repair visit during the service agent’s normal working hours. Any costs incurred by TurboChef or its service agent associated with a service agent being refused or unable to gain access to the Equipment on your premises, or a claim not covered by this warranty, will be charged to you.

Disclaimer of Damages

TurboChef disclaims all incidental, special and consequential damages, including but not limited to loss of use, lost revenue or profits, or substitute use, suffered by you or any third party, whether arising in contract, tort (including negligence), or otherwise, resulting from any breach by TurboChef or its service agents of this warranty, or resulting from the manufacture, use, or defects, of or in the Equipment, even if TurboChef was apprised of the possibility of such damages.

Customer Indemnity

You agree to indemnify, defend and hold TurboChef harmless from all third party claims, demands, judgments, fees and costs directly or indirectly arising out of or related to your use of the Equipment. You further agree to indemnify and hold TurboChef harmless from any incidental, consequential or special damages suffered by you, including lost revenue or profits, loss of use, or substitute use, during periods of Equipment failure or loss of use.

Territory

This warranty is valid in the United States of America, Canada and Puerto Rico.

Governing Law, Entire Warranty

This warranty shall be governed and construed in accordance with the laws of the State of Georgia, USA (except with respect to its provisions regarding conflicts of laws). The warranty described herein is the complete and only warranty for Equipment and supersedes all prior oral or written agreements and understandings that may have existed between us relating to Equipment warranties. The terms of this warranty may not be altered, amended or modified except by a signed writing from TurboChef. Any purported alteration, amendment or modification by a service agent or anyone else will not be enforceable against TurboChef.

Charges for Non-Warranty Service or Rejection of Service Visit

In the event that repairs, replacement or service are provided by TurboChef's service agents for work not covered by this limited warranty, customer agrees to pay the service agent directly according to the service agent's normal scale of charges. In the event TurboChef is invoiced by the service agent for services not covered under this extended warranty, TurboChef will invoice customer and customer will pay such invoice based on terms of net 10 days. Customer also agrees to pay any cost incurred by TurboChef or its service agent associated with a service agent responding to a call for service, but then being refused or unable to gain access to the Oven on Customer's premises. Failure to submit payment may, at TurboChef's discretion, result in TurboChef voiding the balance of the warranty. In no event will TurboChef authorize service to a store with an outstanding Non-Warranty invoice.

International Limited Warranty

This Limited Warranty shall apply to the sales of all TurboChef “i5” Series ovens (the “Equipment”) manufactured by TurboChef Technologies, Inc. (“TurboChef”), and sold to purchasers outside of the United States, Canada, Puerto Rico, Central and South America by an Authorized Distributor of TurboChef International (the “Authorized Distributor”).

Limited Warranty

You, the purchaser (“You”) have entered into a sales contract with the Authorized Distributor for the purchase of the Equipment. This Limited Warranty is made to you by the Authorized Distributor from whom you purchased the Equipment with the support of TurboChef. Subject to the limitations stated below, the Authorized Distributor warrants to You that the quantity and specification of the Equipment delivered to You shall be as set out in the Authorized Distributor’s acceptance of your order and that the Equipment will be free from any material defects in the product and workmanship for twelve (12) months from the date of installation (the “Warranty Period”), subject to the terms and conditions set forth herein.

Disclaimer

You acknowledge that You are solely responsible for the selection of the Equipment and determining the suitability of the Equipment for Your needs. All other warranties, conditions or terms relating to fitness for purpose, quality or condition of the Equipment, whether expressed or implied by statute or common law or otherwise are excluded to the fullest extent permitted by law.

The TurboChef Global Warranty System

This Limited Warranty commences upon delivery of the Equipment to Your premises. The Authorized Distributor will inspect and install the Equipment at Your premises in accordance with TurboChef’s instructions and will record the serial number of the Equipment, Your contact details, the date and location of installation and the results of the Authorized Distributor’s inspection. This information will be entered by the Authorized Distributor into the TurboChef global warranty system and will be used by TurboChef, the Authorized Distributor and its authorized service agents for the provision of the warranty service.

Warranty Service

During the Warranty Period, any materially defective Equipment will be repaired or replaced free of charge at TurboChef’s option provided that:

1. You notify the Authorized Distributor from whom You purchased the Equipment and/or TurboChef as soon as reasonably possible after discovery of a defect and in accordance with the warranty claims procedure set out below;
2. You provide the Authorized Distributor from whom You purchased the Equipment and/or TurboChef with all data and information reasonably requested by TurboChef, the Authorized Distributor or its authorized service agents in connection with Your warranty claim;

3. You make the Equipment available to TurboChef, the Authorized Distributor or its authorized service agents;
4. The Equipment has been installed by an Authorized Distributor and you have provided all necessary information for the Authorized Distributor to register the Equipment in the TurboChef global warranty system;
5. The Equipment has been operated and maintained by You in accordance with TurboChef's "Owner's Manual" provided with the Equipment (and as updated by TurboChef);
6. You have not used any non-approved devices, accessories, consumables or parts in conjunction with the Equipment; and
7. Repairs, modifications or alterations have not been attempted other than by TurboChef, an Authorized Distributor or its authorized service agent.

Neither TurboChef nor the Authorized Distributor assumes any liability for damage caused by Your failure to provide a suitable installation and operating environment (including power and HVAC) or facilities as prescribed by the Manual, misuse or abuse or by accident, neglect, power failure or power surges (over or under voltage) howsoever arising.

At its sole option, TurboChef may replace defective Equipment or components with new, recovered or rebuilt Equipment of equal or greater capability, and such Equipment or components will be warranted by the Authorized Distributor for the balance of the Warranty Period. Replaced defective Equipment or components will become the property of TurboChef.

Warranty Claims: Any warranty claim must be made directly in writing either to the Authorized Distributor from whom You purchased the Equipment or to TurboChef at the following address:

TurboChef Technologies, Inc.
4240 International Parkway, Suite 105
Carrollton, Texas 75007
Phone: +1 214-379-6000
Fax: +1 214-379-6073

The claim must include the serial number of the Equipment and be received by TurboChef on or before the last day of the Warranty Period. Upon receipt of Your claim, TurboChef will promptly notify an Authorized Distributor or an authorized service agent to contact You, to verify Your claim and, if necessary, to arrange for an on-site repair visit during normal working hours.

Consumables and Parts Used with The Equipment: Neither TurboChef nor the Authorized Distributor assumes any liability for consumables and parts that are used in the normal course of Equipment operation or for failure of or damage to Equipment or components from the use of non-approved cleaning chemicals, devices or processes.

Charges for Service Not Covered by Limited Warranty: In the event that You request and receive repairs, replacement or service not covered by this Limited Warranty, You will be invoiced and must pay the Authorized Distributor or authorized service agent directly according to its normal scale of charges and business terms.

Product Liability: Neither TurboChef nor the Authorized Distributor assumes any liability for any incidental, special or consequential damages, including but not limited to loss of use, lost revenue or profits, or substitute use suffered by You or any third party, whether arising in contract, tort (including negligence), or otherwise resulting from any breach by TurboChef or the Authorized Distributor of the Limited Warranty provided herein.

Exclusive Remedy: This Limited Warranty states the Authorized Distributors and TurboChef's sole and exclusive obligation and liability and your sole and exclusive remedy under this Limited Warranty.

Third Party Rights: The UK Contract (Rights of Third Parties) Act 1999 is excluded from applying to this Limited Warranty and nothing herein confers or purports to confer on any third party any benefit or any right to enforce any term of this Limited Warranty.

Severability: If any item or provision contained in this Limited Warranty or any part of them ("an offending provision") is declared to be or becomes unenforceable, invalid or illegal for any reason whatsoever in any jurisdiction, the other terms and provisions of this Limited Warranty shall remain in full force and effect in that jurisdiction as if it had been executed without the offending provision appearing in it and the entire Limited Warranty shall remain in full force and effect in all other jurisdictions.

Governing Law, Entire, Agreement: This Limited Warranty shall be governed by and construed according to English law. The application of the United Nations Convention on International Sale of Goods to this Limited Warranty is expressly excluded. This Limited Warranty may not be altered, amended or modified by the Authorized Distributor or its service agent, and no representation, alteration, amendment or modification by TurboChef shall be valid unless in a signed form from TurboChef.

For service or information:

WITHIN NORTH AMERICA CALL

Customer Service *at* 800.90TURBO or
Sales & Marketing *at* 866.90TURBO

OUTSIDE NORTH AMERICA CALL

+1 214-379-6000 or Your Authorized Distributor



Accelerating the World of Cooking™

Part Number: i5-9227/Revision A/December 2007
Country Code: NA/EU

Corporate Headquarters

Six Concourse Pkwy, Suite 1900
Atlanta, Georgia 30328 USA
+1 678.987.1700 PHONE
+1 678.987.1750 FAX

Sales & Marketing: 866.90TURBO

Global Operations

4240 International Pkwy, Suite 105
Carrollton, Texas 75007 USA
+1 214.379.6000 PHONE
+1 214.379.6073 FAX

Customer Service: 800.90TURBO
+1 214.379.6000

turbochef.com