

PRODUCT:	QTY:	ITEM#
----------	------	-------



Standard Features:

- Portable tabletop design with 18 gauge 304 stainless steel housing, heavy duty electronic components, and high impact ceramic glass top designed for use in the commercial kitchen
- Adjustable rheostat control
- SmarTemp[™] Temperature control allows for 27 precise temperature settings and 20 power cook settings
- Pan Maximizer feature achieves maximum heating of any induction compatible pan
- Microprocessor monitors vital components 120 times per second to check for overheating, power supply problems, and more. Cooktop shuts off and displays error codes enabling user to diagnose and fix minor problems.
- LED Display for precise user feedback
- Automatic pan detection allows for instant energy transmission to pan
- Automatic shut-off feature prohibits overheating
- Sloped front panel allows for easy viewing and operation
- Easy-to-clean glass top surface
- Integral cooling fan keeps internal electronics cool
- Available in 1800 watts (110-120V), 2500, 3000 and 3500 watts (208-240V)
- One year limited warranty
- Made-in-the-USA
- OPTIONS AT NO CHARGE: NEMA plus type standard for U.S. and Canadian destinations. All other countries must specify voltage, duty cycle and required NEMA plus configuration.

Specifications:

Shall be a CookTek free-standing induction cooktop, Model _____ with a total kW rating of _____. Unit shall be manufactured in the United States and constructed of a stainless steel housing and a high impact ceramic glass top. Unit shall be equipped with a built-in SmarTemp[™] microprocessor that performs precise temperature control, auto shut-off to prevent overheating, self-diagnostics, and a pan maximizer feature that ensures maximum heating of any induction compatible pan. Unit shall have adjustable rheostat control with 20 power cook settings and 27 precise temperature settings. Unit shall operate on _____ power with integral cord and plug supplied.

Note: Induction cooking requires the use of magnetic pots and pans.



CookTek
MagnaWave™ Systems

FREE-STANDING INDUCTION COOKTOPS
MC-1800, MC-2500, MC-3000, MC-3500

FREE-STANDING INDUCTION COOKTOPS MC-1800, MC-2500, MC-3000, MC-3500

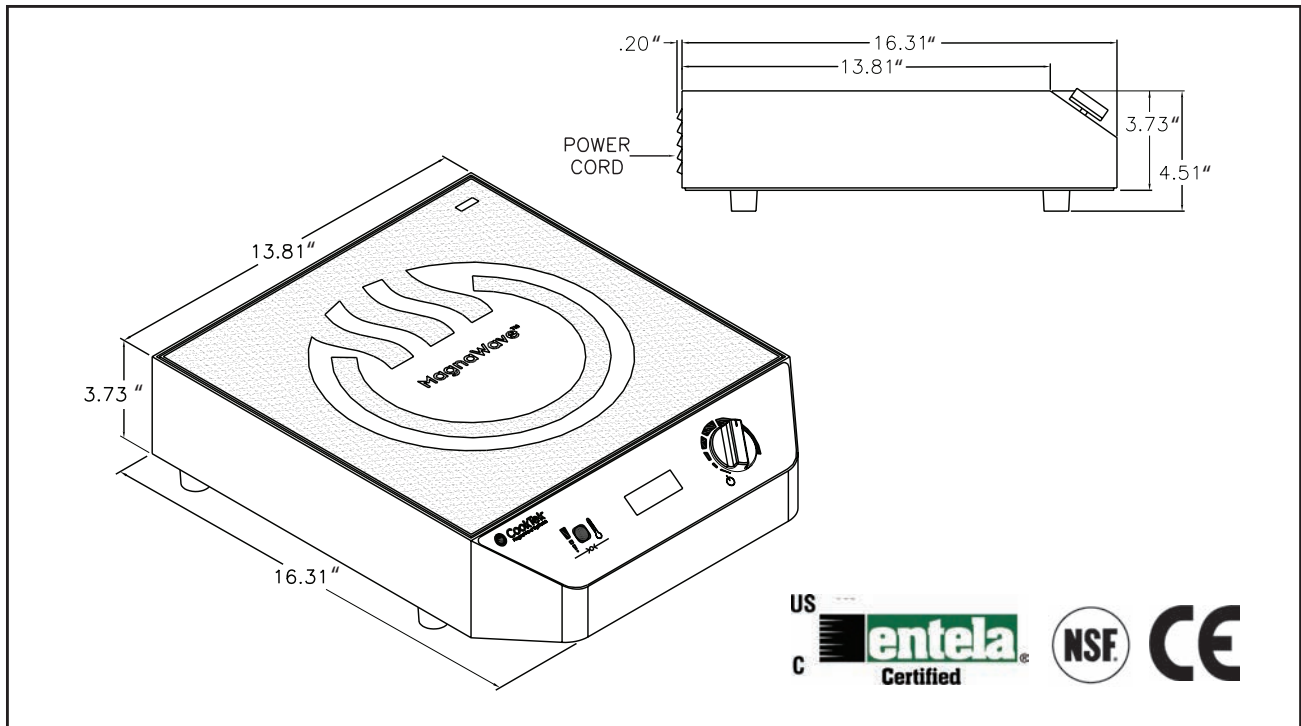

SPECIFICATIONS:

	MC-1800	MC-2500	MC-3000	MC-3500
Power requirements	100-120V, 1PH	200-240V, 1PH	200-240V, 1PH	200-240V, 1 PH
Power consumption	1800 Watts (at max. setting)	2500 Watts (at max. setting)	3000 Watts (at max. setting)	3500 Watts (at max. setting)
BTU comparison	16,000 BTU	22,000 BTU	26,000 BTU	31,000 BTU
Voltage	100-120V 50/60Hz	200-240V 50/60Hz	200-240V 50/60Hz	200-240V 50/60Hz
Amperage	15 amps (at max. setting)	12 amps (at max. setting)	14 amps (at max. setting)	17 amps (at max. setting)
Power range	100-1800W	100-2500W	100-3000W	100-3500W
Temperature range	85 - 500F	85 - 500F	85 - 500F	85 - 500F
Dimensions (inches)	16.31L x 13.81W x 4.51H	16.31L x 13.81W x 4.51H	16.31L x 13.81W x 4.51H	16.31L x 13.81W x 4.51H
Weight	19 lbs	19 lbs	19 lbs	19 lbs
Packaged weight	24 lbs	24 lbs	24 lbs	24 lbs
Packaging dimensions (inches)	20.75L x 18.75W x 9.0H	20.75L x 18.75W x 9.0H	20.75L x 18.75W x 9.0H	20.75L x 18.75W x 9.0H
Cord length & plug*	6 Ft., NEMA 5-15P	6 Ft., NEMA 6-20P	6 Ft., NEMA 6-20P	6 Ft., NEMA 6-20P
Warranty	One year limited warranty	One year limited warranty	One year limited warranty	One year limited warranty
Cooling clearance	2" for front, sides & rear	2" at sides & rear	2" at sides & rear	2" at sides & rea

*IEC Connector for 200V and higher units. International cord length = 8.2ft.

Note: Many local codes exist, and it is the Owner and Installer's responsibility to comply with those codes. It's CookTek's policy to continually improve its products, and we reserve the right to change or improve our specifications without notification.

CookTek
MagnaWave™ Systems

CookTek
810 West Washington Blvd.
Chicago, Illinois 60607 USA
www.cooktek.com

Tel: 1.312.563.9600 Fax: 1.312.432.6222
 Toll Free: 1.888.COOKTEK (266-5835)
 Toll Free Fax: 1.888.COOKFAX (266-5329)

