

PRODUCT:

QTY:

ITEM #:



**Standard Features:**

- Portable tabletop design with powder coated steel, heavy duty electronic components, and high impact, polycarbonate locator
- Microprocessor monitors vital components multiple times per second to check for overheating, power supply problems, and more
- Initial charge in 5 minutes or less
- Recharge in 90 seconds (avg.)
- Lightweight pellet and bag at 5 lbs
- Extremely easy to implement with no pellet cord, no maintenance and no extra labor steps
- Charger housing manufactured and designed for easy installation
- Charger does not emit any heat on the locator surface
- User friendly membrane panel and lighted displays are easy to operate and understand
- Charger manufactured and designed to handle exposure to flour, dust, oil, grease and various other food substances found in food establishments
- Automatic load detection allows for instant energy transmission to bag, and no energy use when load is not present

- Automatic shut-off feature prohibits overheating
- Easy-to-clean, smooth, polycarbonate surface
- Charger shuts off and indicates error codes enabling user to diagnose and fix minor problems
- Integral cooling fan keeps internal electronics cool
- Available in 120V or 240V version
- Bags can be specified with different holding temperatures
- Multiple bag sizes available
- One year limited warranty
- Made in the USA

**Specifications:**

Shall be a CookTek induction Universal Thermal Delivery System, Model \_\_\_\_\_ with a total kW rating of \_\_\_\_\_. Unit shall be manufactured in the United States and constructed of powder coated steel with a polycarbonate locator tray. Unit shall be equipped with SmarTag™ microprocessor that performs precise temperature control, auto shut-off to prevent over-heating, self-diagnostics to ensure consistent heating of induction-compatible loads. Unit shall operate on \_\_\_\_ power with integral cord and plug supplied.

IMPORTANT: Universal Thermal delivery System must be used in conjunction with CookTek approved bags.

**CookTek**  
810 West Washington Blvd.  
Chicago, Illinois 60607 USA  
www.cooktek.com

Tel: 1.312.563.9600 Fax: 1.312.432.6220  
Toll Free: 1.888.COOKTEK (266-5835)  
Toll Free Fax: 1.888.COOKFAX (266-5329)



UNIVERSAL THERMAL DELIVERY SYSTEM

UTDS-100 UTDS-200



**CookTek**<sup>®</sup>  
MagnaWave<sup>™</sup> Systems

UNIVERSAL THERMAL DELIVERY SYSTEM  
UTDS-100 UTDS-200

UNIVERSAL THERMAL DELIVERY SYSTEM

UTDS-100 UTDS-200

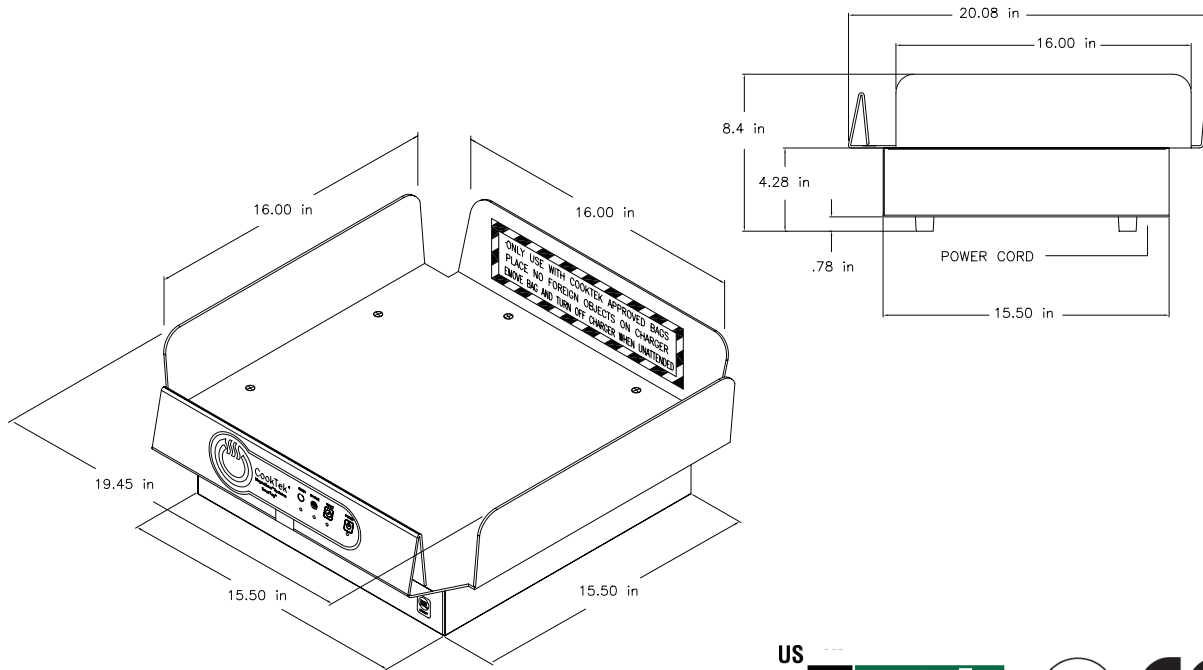

**SPECIFICATIONS**

	<b>UTDS-100</b>	<b>UTDS-200</b>
Model Number		
Power requirements	100-120V, 1PH	200-240V, 1PH
Voltage	100-120VAC, 50/60Hz	200-240VAC, 50/60Hz
Amperage Max	15 amps	7.5 amps
Power	1200 - 1400W	1200-1400 Watts
Charger dimensions (inches)	19.2L x 18.20W x 8.63H	19.2L x 18.20W x 8.63H
Weight (Packaged)	17 lbs. Net / 21 lbs.	17 lbs. Net / 21 lbs.
Cord length and plug type	6 ft., NEMA 5-15P	6 ft., NEMA 6-20P
Warranty	One year limited warranty	One year limited warranty
Cooling clearance	2" front, rear and sides	2" front, rear and sides

**Note:** Many local codes exist, and it is the Owner and Installer's responsibility to comply with those codes. It's CookTek's policy to continually improve its products, and we reserve the right to change or improve our specifications without notification.

**CookTek**  
810 West Washington Blvd.  
Chicago, Illinois 60607 USA  
www.cooktek.com

Tel: 1.312.563.9600 Fax: 1.312.432.6220  
Toll Free: 1.888.COOKTEK (266-5835)  
Toll Free Fax: 1.888.COOKFAX (266-5329)

