



The Wood Stone Bistro

The Bistro 4355 features a standard door opening 24 inches wide x 10 inches high. The cooking surface is 34 inches wide, and 40 inches deep, resulting in 9.4 square feet of usable deck space.

The dense, high temperature ceramic formulation of which the 500 pound, monolithic, cast-ceramic floor and the 725 pound, monolithic dome are cast creates a "deep heat sink" within the chamber of the oven. The hearth and dome are connected by a carefully tensioned stainless steel exoskeleton, which ensures structural integrity and long life. The oven sits on a heavy-duty frame. A stainless steel storage compartment is optional and can be provided in the support frame.

The ceramic interior is heated by a powerful, adjustable radiant burner located in the back of the oven chamber. The burner is controlled exclusively by the chef, the heat distribution in the oven can be adjusted to meet the needs of a variety of menu items. The Bistro can be configured to burn either Natural Gas (methane) or Propane - gas type should be specified at time of order.

The oven arrives fully assembled and ready for installation. Optionally, the oven can be shipped crated and ready for onsite assembly.

The Bistro vents through a 10 inch I.D. flue collar located above the doorway. Our gas ovens are listed for direct venting through a Listed building heating appliance chimney, also listed as grease duct, OR through a Listed Type 1 exhaust hood or one constructed in accordance with all relevant local and national codes. The oven should be vented in accordance with all relevant local and national codes, and in a manner acceptable to the authority having jurisdiction.

Hearth Capacity

8 inch pizzas	12
10 inch pizzas	9
12 inch pizzas	6
16 inch pizzas	4

Optional Accessories

- **Stainless Steel Oven Tool Set (with stainless steel hangers)**
- **Stack-Mounted Exhaust Fan**
- **Wood Stone also manufactures a full line of accessories for stone hearth cooking**
- **Configured for wood burning**

Wood Stone Corporation

 1801 W. Bakerview Rd.
 Bellingham, WA 98226 USA

Toll Free (800) 988-8103

Tel (360) 650-1111

Fax (360) 650-1166

Bistro 4355

Stone Hearth
Baking and Roasting Oven

Model

WS-BL-4355-RFG

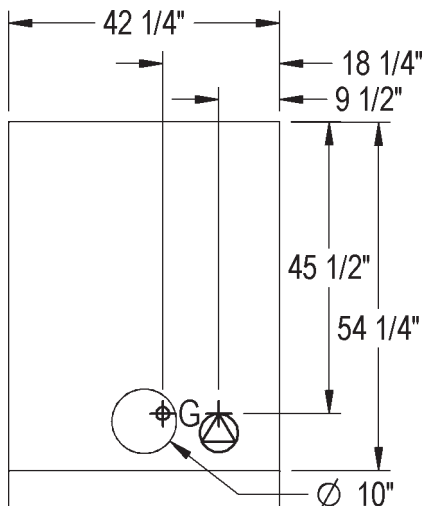
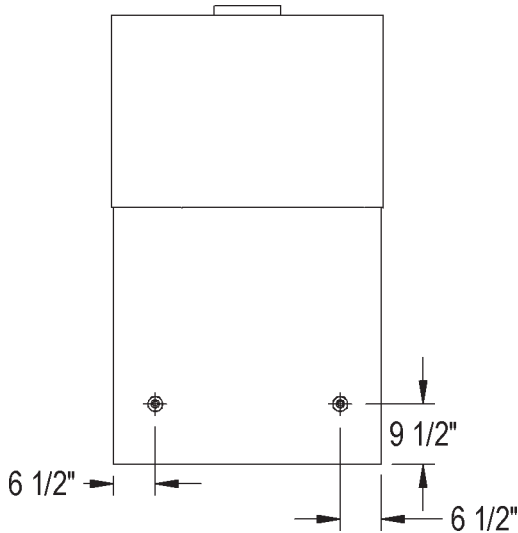
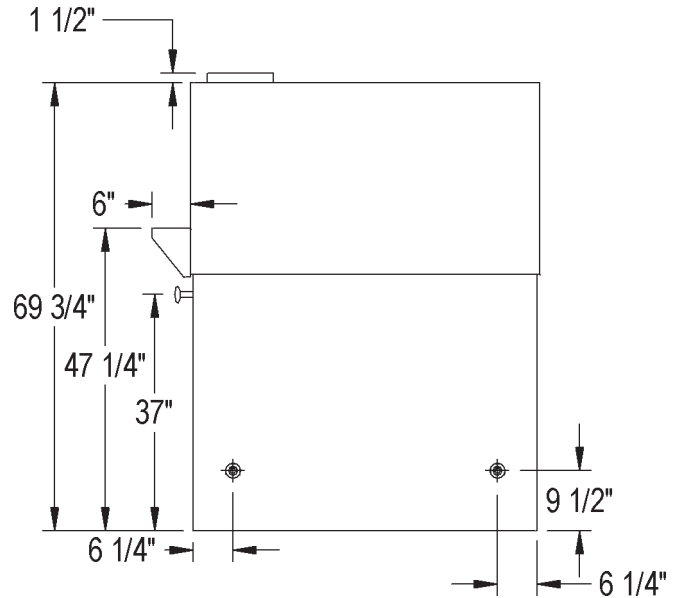
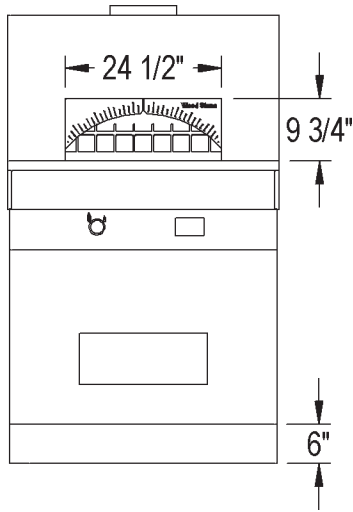

**Actual Weight 2100 LBS.
Shipping Weight: 2500 LBS.**

Utility Specifications

Gas-3/4 inch gas inlet (female threaded)

80,500 Btu Natural Gas

or

68,000 Btu Propane

Electrical

120 VAC, 2 amp, 50/60 Hz

All utility connections made on the back of the oven control box. Remove front or rear panel for access, use utility knockouts (provided) to route gas and electrical supplies.

Venting

Our gas ovens are listed for direct venting through a power-ventilated, Listed building heating appliance chimney, also Listed as a grease duct, OR through a Listed Type 1 exhaust hood or one constructed in accordance with all relevant local and national codes. This appliance should be vented in accordance with all relevant local and national codes.



Wood Stone Corporation

1801 W. Bakerview Rd.
Bellingham, WA 98226 USA

Toll Free (800) 988-8103

Tel (360) 650-1111

Fax (360) 650-1166